

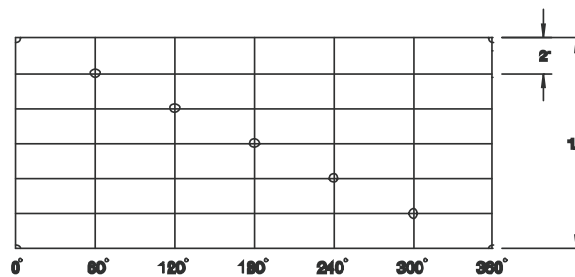

ITEM	PART NO.	DESCRIPTION
1	S239-0634-A04	Threaded Shipping Assembly, 2.390 OD X 4 FT, 6 SPF, 60°, 19 Shots
	S239-0634-A07	Threaded Shipping Assembly, 2.390 OD X 7 FT, 6 SPF, 60°, 37 Shots
	S239-0634-A11	Threaded Shipping Assembly, 2.390 OD X 11 FT, 6 SPF, 60°, 61 Shots
	S239-0634-A15	Threaded Shipping Assembly, 2.390 OD X 15 FT, 6 SPF, 60°, 85 Shots
	S239-0634-A21	Threaded Shipping Assembly, 2.390 OD X 21 FT, 6 SPF, 60°, 121 Shots
2	T150-0634-A04	Tube Strip, 1.500 OD X 4 FT, 6 SPF, 60°
	T150-0634-A07	Tube Strip, 1.500 OD X 7 FT, 6 SPF, 60°
	T150-0634-A11	Tube Strip, 1.500 OD X 11 FT, 6 SPF, 60°
	T150-0634-A15	Tube Strip, 1.500 OD X 15 FT, 6 SPF, 60°
	T150-0634-A21	Tube Strip, 1.500 OD X 21 FT, 6 SPF, 60°
3	C239-0600-A04	Threaded Carrier, 2.375 OD X 4 FT, 6 SPF, 60°
	C239-0600-A07	Threaded Carrier, 2.375 OD X 7 FT, 6 SPF, 60°
	C239-0600-A11	Threaded Carrier, 2.375 OD X 11 FT, 6 SPF, 60°
	C239-0600-A15	Threaded Carrier, 2.375 OD X 15 FT, 6 SPF, 60°
	C239-0600-A21	Threaded Carrier, 2.375 OD X 21 FT, 6 SPF, 60°
C	TAG-2375-402NT	Charge, HMX, SDP
	TAG-2375-301BH	Charge, RDX, BH

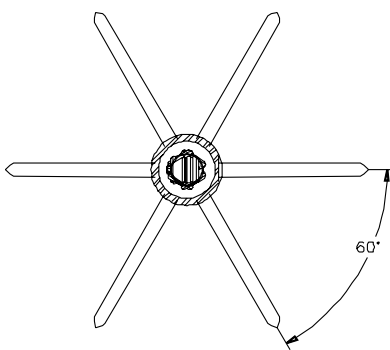

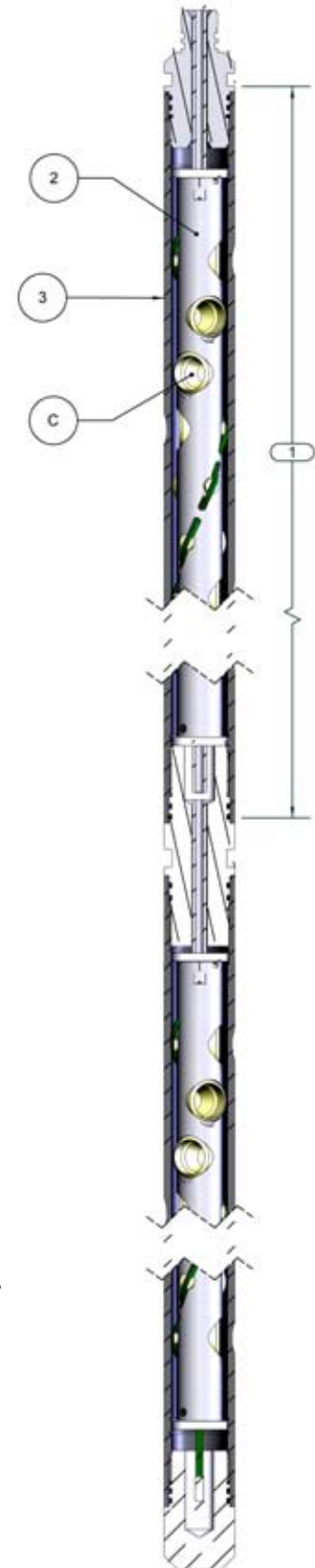

SPECIFICATIONS		
Pressure Rating	137.9 Mpa	20,000 psi
Temperature	UP TO 260°C	UP TO 500°F
Tensile Strength	60 900 daN	137,000 lbf
Carrier Thread	2.030 - 8 STUB ACME	
Gun Weight Loaded	11.1 kg/m	7.44 lb/ft

ITEM	PART NO.	DESCRIPTION
4	TAG-2390-280	Top Sub 2-3/8"
4A	TAG-2390-112	Top Sub 2-3/8" Wireline Systems
5	TAG-2390-281	Tandem Sub 2-3/8"
6	TAG-2390-078	Bull Plug 2-3/8"
7	G250-0100-275	Booster Transfer Kit
	G250-0100-275T	Torlon Booster Transfer Kit, (High Temp)
8	DET-0100-058	Detonating Cord End Cover (40gr. Ribbon - 40gr. Round)
9	OOO-N569-215	O-Ring, #215, 90 Duro Nitrile - see ref. section
	OOO-V569-215	O-Ring, #215, 90 Duro Viton - see ref. section
10	OOO-N569-225	O-Ring, #225, 90 Duro Nitrile - see ref. section
	OOO-V569-225	O-Ring, #225, 90 Duro Viton - see ref. section
11	AES-AS80005	Firing Adapter Assy., 1.50 O.D.
12	OOO-N569-214	O-Ring, #214, 90 Duro Nitrile - see ref. section
	OOO-V569-214	O-Ring, #214, 90 Duro Viton - see ref. section
13	AES-4244	Shooting Adapter Assy., 1-11/16" O.D.
A	A538010	Detonating Cord, 40 gr. Ribbon, RDX, LS - see ref. section
	A539010	Detonating Cord, 40 gr. Round, RDX, LS - see ref. section
	A545010	Detonating Cord, 40 gr. Ribbon, HMX, LS - see ref. section
	A544010	Detonating Cord, 40 gr. Round, HMX, LS - see ref. section
B	DET-3050-429	Bi-Directional Booster
	DET-0010-006	40 grain rubber grommet - to std Bi-Directional Booster

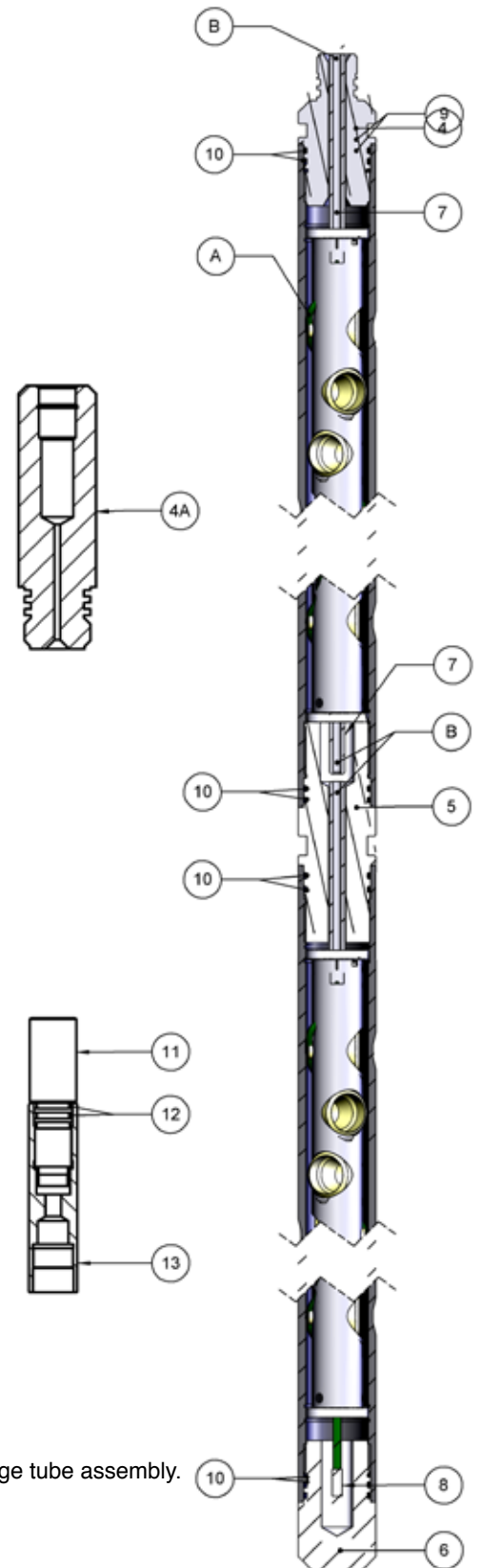

This gun system uses a keyway inside the carrier to orient an alignment pin on the charge tube assembly. This "True Shot Interval" gun incorporates 1 additional charge to obtain 6.0" to top shot. This gun system is fully compatible with existing Owen Oil Tools gun subs. Refer to page 1 for available lengths. Charges and ancillary components for higher temperature applications are available by Special Order.