

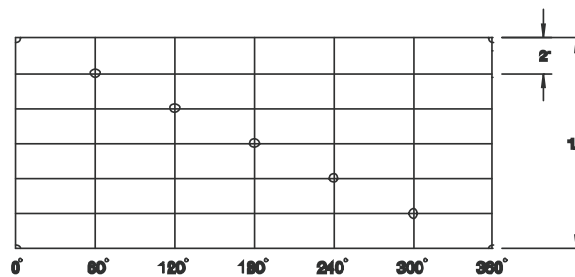

ITEM	PART NO.	DESCRIPTION
1	S156-0638-A04	Threaded Shipping Assembly, 1.563 OD X 4 FT, 6 SPF, 60°, 19 Shots
	S156-0638-A07	Threaded Shipping Assembly, 1.563 OD X 7 FT, 6 SPF, 60°, 37 Shots
	S156-0638-A11	Threaded Shipping Assembly, 1.563 OD X 11 FT, 6 SPF, 60°, 61 Shots
	S156-0638-A15	Threaded Shipping Assembly, 1.563 OD X 15 FT, 6 SPF, 60°, 85 Shots
	S156-0638-A21	Threaded Shipping Assembly, 1.563 OD X 21 FT, 6 SPF, 60°, 121 Shots
2	T106-0638-A04	Tube Strip, 1.063 OD X 4 FT, 6 SPF, 60°
	T106-0638-A07	Tube Strip, 1.063 OD X 7 FT, 6 SPF, 60°
	T106-0638-A11	Tube Strip, 1.063 OD X 11 FT, 6 SPF, 60°
	T106-0638-A15	Tube Strip, 1.063 OD X 15 FT, 6 SPF, 60°
	T106-0638-A21	Tube Strip, 1.063 OD X 21 FT, 6 SPF, 60°
3	C156-0600-A04	Threaded Carrier, 1.563 OD X 4 FT, 6 SPF, 60°
	C156-0600-A07	Threaded Carrier, 1.563 OD X 7 FT, 6 SPF, 60°
	C156-0600-A11	Threaded Carrier, 1.563 OD X 11 FT, 6 SPF, 60°
	C156-0600-A15	Threaded Carrier, 1.563 OD X 15 FT, 6 SPF, 60°
	C156-0600-A21	Threaded Carrier, 1.563 OD X 21 FT, 6 SPF, 60°
C	RTG-1687-301	Charge, RDX, DP
	RTG-1687-301BH	Charge, RDX, BH
	SDP-1687-402NT3	Charge, HMX, NT3 - HERO™™
	SDP-1687-401NTX	Charge, HMX, SDP
	RTG-1687-401NT	Charge, HMX, SDP
	RTG-1687-401BH	Charge, HMX, BH

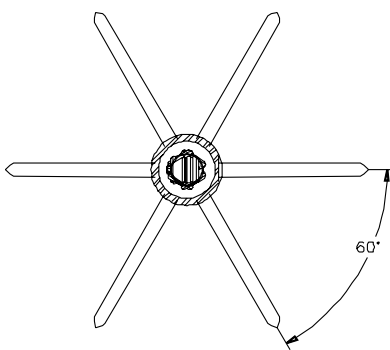

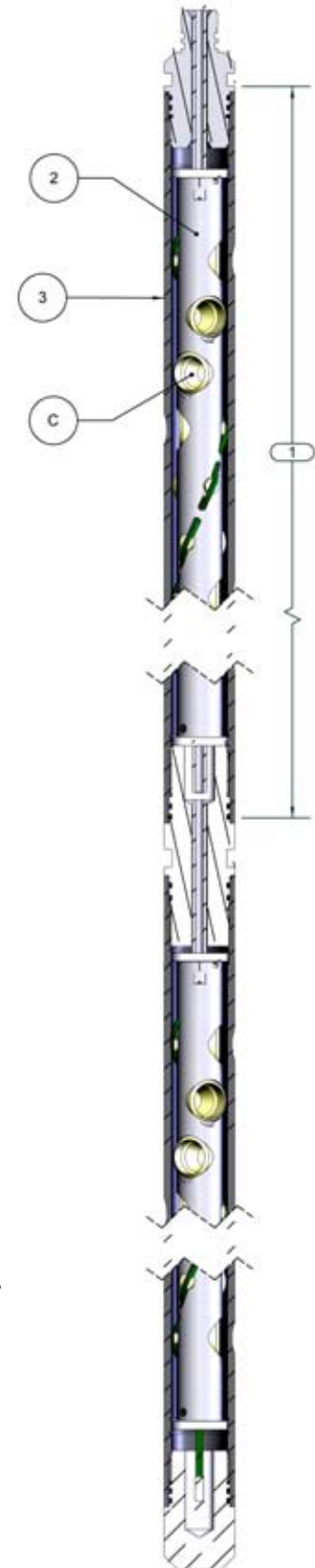

SPECIFICATIONS		
Pressure Rating	158.6 Mpa	23,000 psi
Temperature	UP TO 260°C	UP TO 500°F
Tensile Strength	28 470 daN	64,000 lbf
Carrier Thread	1-9/32" - 12 STUB ACME	
Gun Weight Loaded	4.25 kg/m	2.86 lb/ft

ITEM	PART NO.	DESCRIPTION
4	TAG-1687-280	Top Sub 1-11/16"
4A	TAG-1687-112	Top Sub 1-11/16" Wireline Systems
5	TAG-1687-281	Tandem Sub 1-11/16"
6	TAG-1687-078	Bull Plug 1-11/16"
7	G250-0100-275	Booster Transfer Kit
	G250-0100-275T	Torlon Booster Transfer Kit, (High Temp)
8	DET-0100-058	Detonating Cord End Cover (40gr. Ribbon - 40gr. Round)
9	OOO-N569-215	O-Ring, #215, 90 Duro Nitrile - see ref. section
	OOO-V569-215	O-Ring, #215, 90 Duro Viton - see ref. section
10	OOO-N569-215	O-Ring, #215, 90 Duro Nitrile - see ref. section
	OOO-V569-215	O-Ring, #215, 90 Duro Viton - see ref. section
11	AES-AS80005	Firing Adapter Assy., 1.50 O.D.
12	OOO-N569-214	O-Ring, #214, 90 Duro Nitrile - see ref. section
	OOO-V569-214	O-Ring, #214, 90 Duro Viton - see ref. section
13	AES-4244	Shooting Adapter Assy., 1-11/16" O.D.
A	DET-0325-011	Detonating Cord, 40 gr. Ribbon, RDX, LS - see ref. section
	DET-0325-013	Detonating Cord, 40 gr. Round, RDX, LS - see ref. section
	DET-0412-006	Detonating Cord, 40 gr. Ribbon, HMX, LS - see ref. section
	DET-0412-014	Detonating Cord, 40 gr. Round, HMX, LS - see ref. section
B	DET-3050-429	Bi-Directional Booster
	DET-0010-006	40 grain rubber grommet - to std Bi-Directional Booster

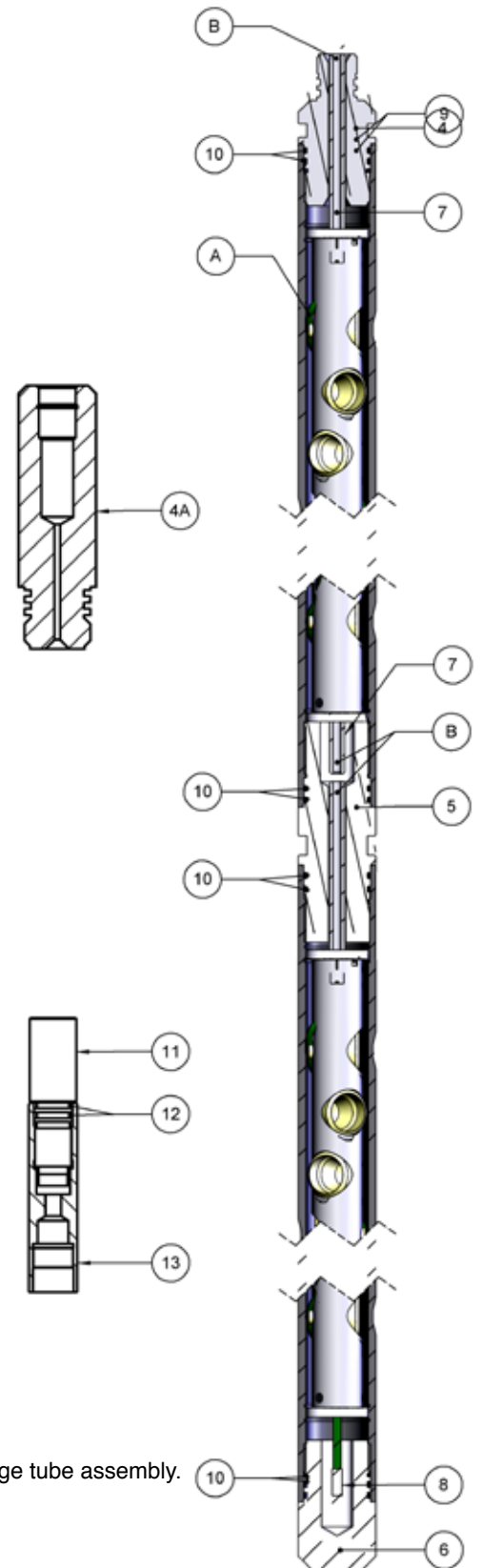

This gun system uses a keyway inside the carrier to orient an alignment pin on the charge tube assembly. This "True Shot Interval" gun incorporates 1 additional charge to obtain 6.0" to top shot. This gun system is fully compatible with existing Owen Oil Tools gun subs. Refer to page 1 for available lengths. Charges and ancillary components for higher temperature applications are available by Special Order.