

CASING O.D. (inch)	4.500	
CASING WT. (T&C) (lb/ft)	17.7	18.9
CASING I.D. (inch)	3.696	3.640
PATCH MAX. RUNNING O.D. (inch)	3.485	
PATCH I.D. AFTER SETTING (inch)	2.930	
PATCH HYDRAULIC BURST RATING (p.s.i)	10000	
PATCH HYDRAULIC COLLAPSE RATING (p.s.i)	10000	
SYSTEM MATERIAL	13 CHROME	

ITEM	CASING O.D. (INCH)	REQ'D.	PART NUMBERS	
SHORT ASSY.-ITEMS 1-9			PAT-4500-0177-3001	PAT-4500-0189-3001
1	PIN ELEMENT	1	PAT-4500-0189-3210	
2	BOX ELEMENT	1	PAT-4500-0189-3410	
3	TOP SWAGE	1	PAT-4500-0177-3110	PAT-4500-0189-3110
4	BOTTOM SWAGE	1	PAT-4500-0177-3310	PAT-4500-0189-3310
5	PIN O-RING	"N"+1	OOO-V569-151	
6	BOX O-RING	"N"+1	OOO-V569-152	
7	RELEASE RING	1	PAT-4500-047 (60K)	PAT-4500-038S (72K)
8	SET SCREW	1	NA	
9	10-FT. SECTION	"N"	PAT-4500-0189-3010 (3.485 X 2.930) 13 Cr L80	
	5-FT. SECTION	OPT.	PAT-4500-0189-3005 (3.485 X 2.930) 13 Cr L80	
10	PIN THREAD PROTECTOR	"N"	PAT-4500-0189-1910	
11	BOX THREAD PROTECTOR	"N"	PAT-4500-0189-1920	
12	SETTING TOOL		SET-3250-000 (3-1/4" O.D. MULTI-STAGE)	
13	SLEEVE NUT	1	SET-3250-420	
14	SLEEVE LOCK NUT	1	SET-3250-421	
15	SETTING SLEEVE ASSY.	1	SET-3250-411A	
-	SETTING SLEEVE (In item 15)		N/A	
-	BOTTOM GUIDE (In item 15)		N/A	
16	QUICK CHANGE ROD	1	SET-3250-130	
17	QUICK CHANGE NUT	1	SET-3250-131	
18	TOP ROD LOCK NUT	1	SET-3500-025	
19	TOP ADAPTER ROD	1	SET-3250-132	
20	ROD TANDEM CONNECTOR	"N"+1	SET-3250-133	
21	10-FT. ROD	"N"	SET-3250-134	
	5-FT. ROD	OPT.	SET-3250-135	
22	BOTTOM ROD	1	SET-3250-136L	
23	COLLET ASSY.	1	SET-3250-460	
-	COLLET BODY (In item 23)	1	SET-3250-461	
-	END SUB (In item 23)	1	SET-3250-449	
24	COLLET SUPPORT	1	SET-3250-446S	
25	ROD SUPPORT	"N"	SET-3250-142C	
26	BOTTOM ADAPTER	"N"	SET-3250-431	

NOTE: "N"=PATCH LENGTH (IN FEET) DIVIDED BY 10

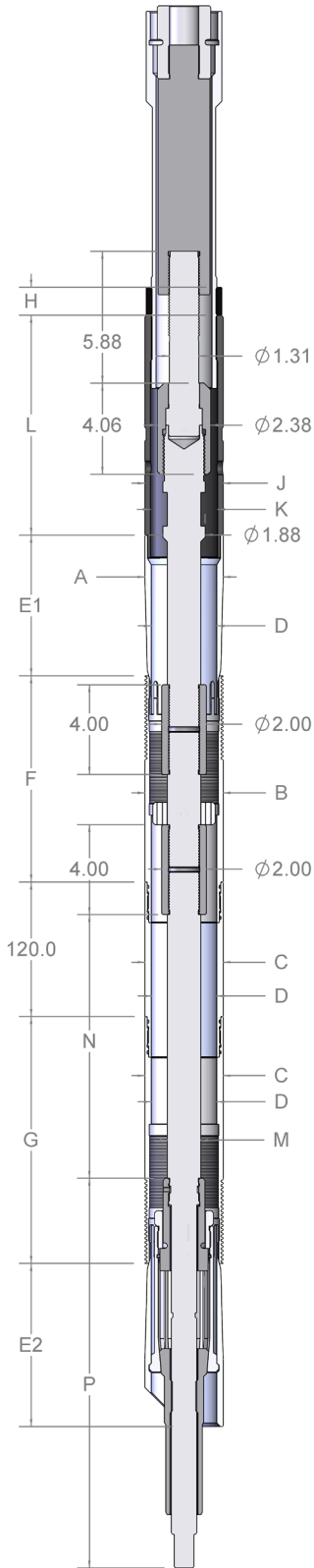

CASING O.D. (inch)	4.5	
CASING WT. (lb/ft)	18.9	17.7
CASING I.D. (inch)	3.640	3.696
MAX RUNNING O.D. (inch)	3.485	
I.D. AFTER SETTING (inch)	2.930	
BURST HYDRAULIC RATING (p.s.i)	10000	
COLLAPSE HYDRAULIC RATING (p.s.i)	10000	
DESCRIPTION		
ITEM	PAT-4500-0189-3001	PAT-4500-0177-3001
A	3.485	
B	3.485	
C	3.485	
D	2.930	
E1	5.772	
E2	6.772	
F	9.185	
G	11.000	
H	1.250	
J	3.485	
K	3.000	
L	9.799	
M	1.500	
N	11.750	
P	17.370	

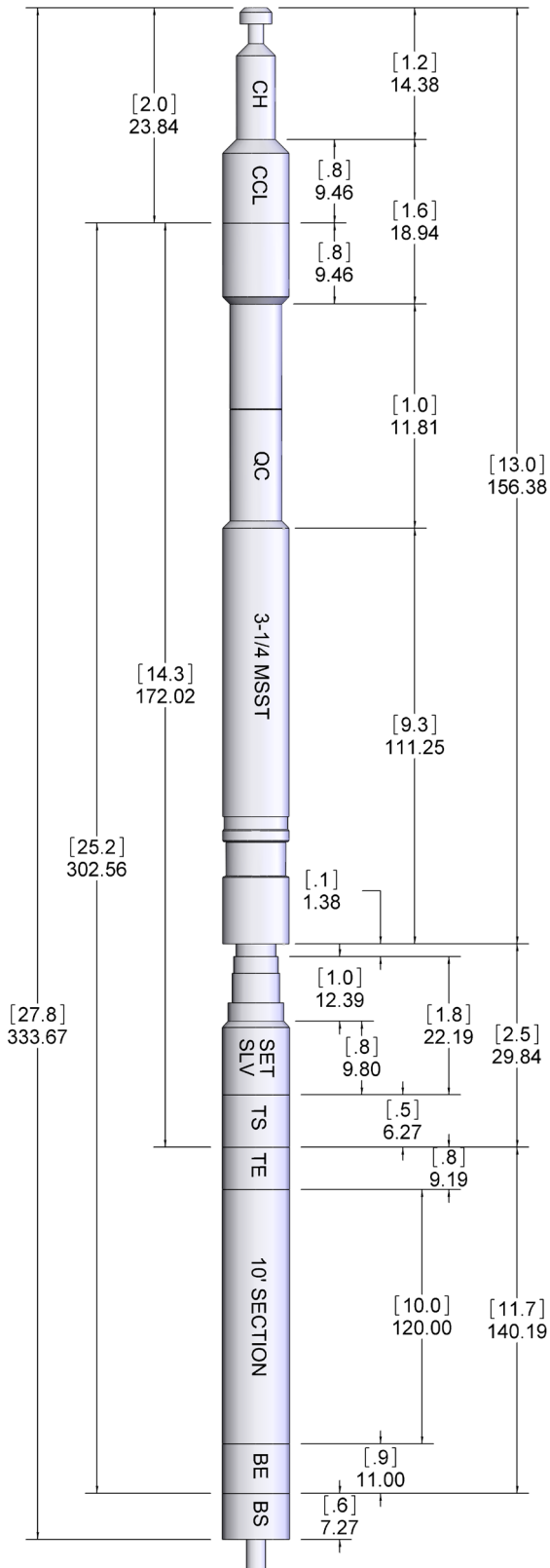

4.500" X-SPAN™ WEIGHTS (LBS)	
DESCRIPTION	WEIGHT
CABLE HEAD	4
3-1/4 CCL	36
3-1/4 Q.C.	14
3-1/4 MSST	206
TOTAL	260

PAT-4500-XXXX-3001	
DESCRIPTION	WEIGHT
PAT. SHORT ASSY.	22
*10-FT. SECTION	93
*10-FT. ROD	61
*TAND. COUPL.	2
*ROD SUPPORT	2
Q.C. ROD	3
Q.C. NUT	2
TOP ROD	8
BOTTOM ROD	11
SLEEVE NUT	7
SLEEVE LOCK NUT	1
SETTING SLEEVE	8
COLLET ASSEMBLY	4
COLLET SUPPORT	3
TOTAL	227

TOTAL WEIGHT	487
---------------------	------------

*EA. ADDITIONAL 10-FT. LGTH ADD 158 LBS.