

## Description

The Fill/Flow Sub is a ported device that allows the production tubing/perforating string to fill while running, as well as acting as a flow passage for reservoir fluids to enter the tubing during production. The Fill/Flow Sub features a thin glass disk which keeps debris from settling on top of the Firing Head which may affect operation of the Firing Head

The Glass Disk is not sealed and does not hold any differential pressure.

## Features and Benefits

- Simple design is easy to service and redress
- Large ports give greater flow area than the tubing bore

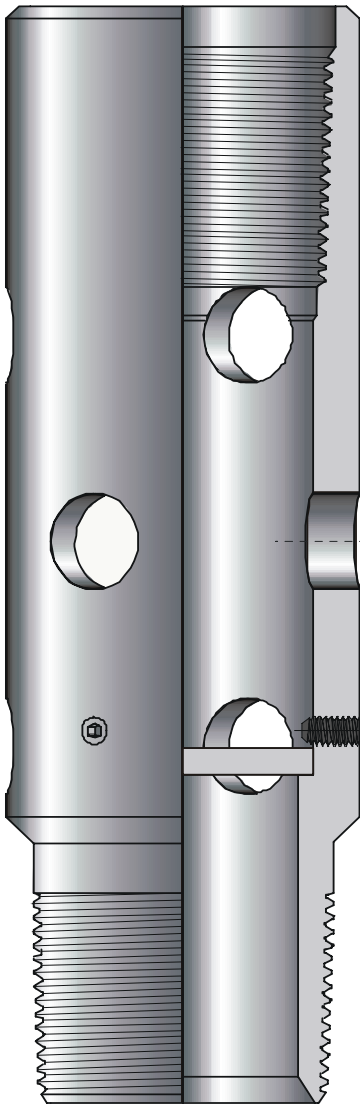

## Specifications

	2-3/8 in (60.3 mm)		2-7/8 in (73.0 mm)		3-1/2 in (88.0 mm)	
Maximum OD	3.062 in	77.8 mm	3.688 in	93.6 mm	4.500 in	114.3 mm
Minimum ID	1.995 in	50.6 mm	2.441 in	62.0 mm	2.992 in	76.0 mm
Maximum Temp	450°F (230°C)					
Flow Area <sup>1</sup>	5.4 in <sup>2</sup>	3483 mm <sup>2</sup>	7.07 in <sup>2</sup>	4561 mm <sup>2</sup>	7.06 in <sup>2</sup>	4554 mm <sup>2</sup>
Connection	2-3/8 in (60.3 mm) EU		2-7/8 in (73.0 mm) EU		3-1/2 in (88.0 mm) EU	
Number of Ports	9		9		4	
Product Number	40-030-2375-00		40-030-2875-00		40-030-3500-00	
Redress Kit	40-030-2375-99		40-030-2785-99		40-030-3500-99	

<sup>1</sup>Greater flow area than the tubing bore

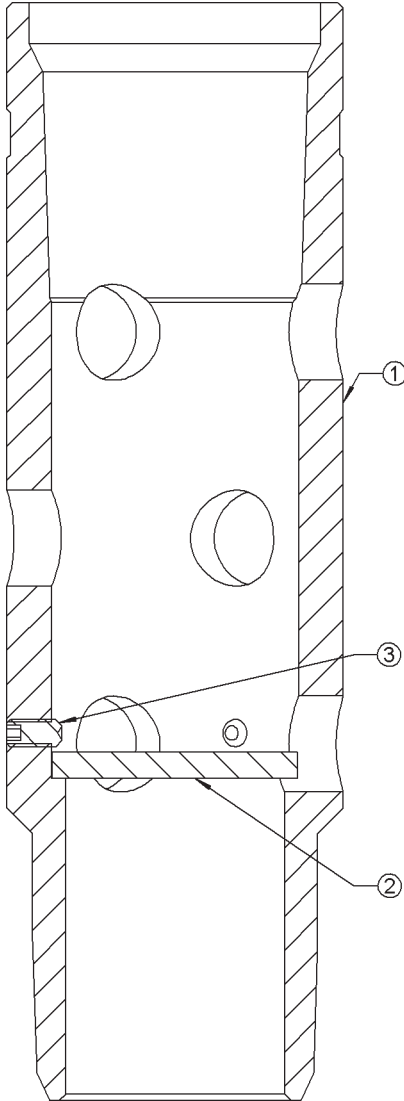

Item	Part Number	Qty	Description
--	<b>40-030-2375-00</b>	--	<b>Fill Flow Sub 2-3/8" EU</b>
1	40-030-0000-00	1	Fill Flow Body 2-3/8" EU
2	TC-100-0001-225C	1	Glass Disk, 2-3/8" Fill Sub 6mm Thick
3	PF-001-025C-050S	3	Set Screw SO 1/4"-20 UNC x 1/2 Steel

Item	Part Number	Qty	Description
--	<b>40-030-2875-00</b>	--	<b>Fill Flow Sub 2-7/8" EU</b>
1	40-030-0002-00	1	Fill Flow Body 2-7/8" EU
2	TC-100-0001-275C	1	Glass Disk, 2-7/8" Fill Sub 6mm Thick
3	PF-001-025C-050S	3	Set Screw SO 1/4"-20 UNC x 1/2 Steel

Item	Part Number	Qty	Description
--	<b>40-030-3500-00</b>	--	<b>Fill Flow Sub 3-1/2" EU</b>
1	40-030-0006-00	1	Body Fill Flow 3-1/2" EU
2	TC-100-0001-325C	1	Glass Disk, 3-1/2" Fill Sub 6mm Thick
3	PF-001-025C-050SS	3	Set Screw SO 1/4"-20 UNC x 1/2 Stainless

Item	Part Number	Qty	Description
--	<b>40-030-2375-99</b>	--	<b>Redress Kit Fill Flow 2-3/8" EU</b>
	TC-100-0001-225C	1	Glass Disk, 2-3/8" Fill Sub 6mm Thick
	PF-001-025C-050S	3	Set Screw SO 1/4"-20 UNC x 1/2 Steel

Item	Part Number	Qty	Description
--	<b>40-030-2875-99</b>	--	<b>Redress Kit Fill Flow 2-7/8" EU</b>
	TC-100-0001-275C	1	Glass Disk, 2-7/8" Fill Sub 6mm Thick
	PF-001-025C-050S	3	Set Screw SO 1/4"-20 UNC x 1/2 Steel

Item	Part Number	Qty	Description
--	<b>40-030-2875-98</b>	--	<b>Redress Kit Fill Flow Sub 2-7/8" Vam</b>
	TC-100-0005-268	1	Glass Disk 2.688 OD X 0.236 Thick
	PF-001-025C-050SS	2	Set Screw SO 1/4"-20 UNC x 1/2 Stainless

Item	Part Number	Qty	Description
--	<b>40-030-3500-99</b>	--	<b>Redress Kit Fill Flow 3-1/2" EU</b>
	TC-100-0001-325C	1	Glass Disk, 3-1/2" Fill Sub 6mm Thick
	PF-001-025C-050SS	3	Set Screw SO 1/4"-20UNC x 1/2 Stainless