



Shogun Spiral Strip/Shogun Snake Technical Manual

MAN-STP1-001 (R10)

Owen Oil Tools LP

12001 CR 1000

Godley, Texas, 76044, USA

Phone: +1 (817) 551-0540

Fax: +1 (817) 551-1674

www.corelab.com/owen

Warning: Use of Owen equipment contrary to manufacturer's specifications or operating instructions may result in property damage, serious injury or fatality. If you are not trained in the handling and use of explosive devices, do not attempt to use or assemble any Owen perforating systems or Owen firing devices.

This technology is regulated by and, if exported, was exported from the United States in accordance with the Export Administration Regulations (EAR). Diversion contrary to U.S. law is prohibited. Export and/or re-export of this technology may require issuance of a license by the Bureau of Industry and Security (BIS), U.S. Department of Commerce. Consult the BIS, the EAR, and/or Owen Compliance Services, Inc. to determine licensing requirements for export or re-export of this technology.

This document contains Confidential Information of Owen Oil Tools LP (Owen) and is furnished to the customer for information purposes only. This document must not be reproduced in any way whatsoever, in part or in whole, or distributed outside the customer organization, without first obtaining the express written authorization of Owen. This document is the property of Owen and returnable upon request of Owen.

© 2010 Owen Oil Tools

Shogun Spiral Strip/Shogun Snake



Shogun Spiral Strip, BOM and Schematics

Item	Part Number	Description
1	STP-1687-284	1-11/16" O.D., Firing Head, Spiral Shogun
	STP-2125-284	2-1/8" O.D., Firing Head, Spiral Shogun
	STP-2500-284	2-1/2" O.D., Firing Head, Spiral Shogun
2	PUR-6000-005	Seizing Cord
	SWG-0000-004	Seizing Wire
3	STP-1687-209	1-11/16" Det Cord Protector Sleeve Assy. (w/ Retainer)
	STP-2125-209	2-1/8" & 2-1/2" Det Cord Protector Sleeve Assy. (w/ Retainer)
4	STP-2125-116	Det Cord Charge Clip, all sizes, included w/charge
5	STP-1687-236HS	Strip, 1-11/16" Shogun, 60°/360°, 4 s hots/ft, 10' HS
	STP-1687-232HS	Strip, 1-11/16" Shogun, 40°/360°, 6 s hots/ft, 10' HS
	STP-2125-236HS	Strip, 2-1/8" Shogun, 60°/360°, 4 sho ts/ft, 10' HS
	STP-2125-232HS	Strip, 2-1/8" Shogun, 40°/360°, 6 sho ts/ft, 10' HS
	STP-2500-232S	Strip, 2-1/2" Shogun, 60°/360°, 4 shot s/ft, 10' S
6	STP-1687-084	3/8"-16 x 3/4" Bolt and Nut Set
7	STP-1687-288	Guide Nose, 1-11/16" Spiral Shogun
	STP-2125-288	Guide Nose, 2-1/8" Spiral Shogun
	STP-2500-288	Guide Nose, 2-1/2" Spiral Shogun
	STP-1687-172	Heavy Guide Nose, 1-11/16" Spiral Shogun
8	STP-2125-172	Heavy Guide Nose, 2-1/8" Spiral Shogun
	STP-2500-172	Heavy Guide Nose, 2-1/2" Spiral Shogun
	STP-1687-229	2' Top Blank / Stiffener, 1-11/16" Spiral Shogun
9	STP-2125-229	2' Top Blank / Stiffener, 2-1/8" Spiral Shogun
	STP-2500-229	2' Top Blank / Stiffener, 2-1/2" Spiral Shogun
	STP-1687-013	3/8"-16 x 1" Bolt and Nut Set - For 1-11/16" & 2-1/8" Top Sub
10	STP-1687-036	3/8"-16 x 1-1/4" Bolt and Nut Set - For 2-1/2" Top Sub
	STP-1687-185	Tandem, 1-11/16" Spiral Shogun
11	STP-2125-185	Tandem, 2-1/8" Spiral Shogun
	STP-2500-185	Tandem, 2-1/2" Spiral Shogun
	STP-2125-208	2-1/8" & 2-1/2" Det. Cord Retainer - for blank intervals on strip
12	STP-1687-208	1-11/16" Det. Cord Retainer - for blank intervals on strip
	AES-AS60030	Magnetic Decentralizer, For 1-11/16" Spiral Shogun
13	DEC-2125-000	Magnetic Decentralizer, For 2-1/8" & 2-1/2" Spiral Shogun
13	AES-AS50029	Adapter Cablehead to expendable
A	A578010	Det Cord, 80 Grain RDX-LS
	A571010	Det Cord, 80 Grain HMX
	A576010	Det Cord, 80 Grain HMX Teflon
C	STP-1687-401NTX	Charge, 1-11/16" Spiral Shogun NTX, HMX, SDP
	STP-1687-401NT	Charge, 1-11/16" Spiral Shogun NT, HMX, SDP
	STP-1687-401NB	Charge, 1-11/16" Spiral Shogun NT, HMX, BH
	STP-2125-401NTX	Charge, 2-1/8" Spiral Shogun NTX, HMX, SDP
	STP-2125-401NT	Charge, 2-1/8" Spiral Shogun NT, HMX, SDP
	STP-2125-401NB	Charge, 2-1/8" Spiral Shogun NT, HMX, BH
	STP-2500-401NT	Charge, 2-1/2" Spiral Shogun NT, HMX, SDP
	STP-2500-401NTXII	Charge, 2-1/2" Spiral Shogun NTXII, HMX, SDP
D	--	Resistorized Detonator (see Det. Ref. Section)
-	STP-1687-162	Alignment Tool Kit for NT Charge
-	STP-1687-164	1-11/16" Shogun Tightening Tool
-	STP-2125-164	2-1/8" Shogun Tightening Tool
-	STP-2500-164	2-1/2" Shogun Tightening Tool
-	MAN-STP1-001	Manual, Spiral Shogun Strip/Shogun Snake

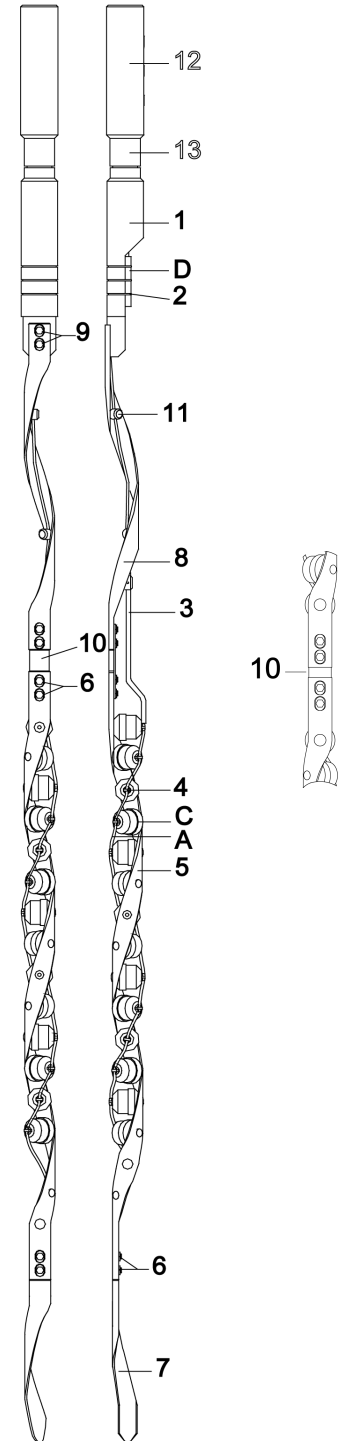

Shogun Spiral Strip/Shogun Snake

Shogun Snake, BOM and Schematics

Item	Part Number	Description
1	STP-1687-284 STP-2125-284	1-11/16" O.D., Firing Head, Spiral Shogun 2-1/8" O.D., Firing Head, Spiral Shogun
2	PUR-6000-005 SWG-0000-004	Seizing Cord Seizing Wire
3	STP-1687-209 STP-2125-209	1-11/16" Det Cord Protector Sleeve Assy. (w/ Retainer) 2-1/8" & 2-1/2" Det Cord Protector Sleeve Assy. (w/ Retainer)
4	STP-2125-116	Det Cord Charge Clip, all sizes, included w/ charge
5	STP-1687-168	Strip, 1-11/16" Shogun Snake, 0°+22.5°+45°+22.5°/0°-22.5°-45°-22.5°; 6 sh ots/ft, 10'
	STP-2125-168	Strip, 2-1/8" Shogun Snake, 0°+22.5°+45°+22.5°/0°-22.5°-45°-22.5°; 6 sh ots/ft, 10'
6	STP-1687-084	3/8"-16 x 3/4" Bolt and Nut Set
7	STP-1687-288	Guide Nose, 1-11/16" Spiral Shogun
	STP-2125-288	Guide Nose, 2-1/8" Spiral Shogun
	STP-1687-172	Heavy Guide Nose, 1-11/16" Spiral Shogun
	STP-2125-172	Heavy Guide Nose, 2-1/8" Spiral Shogun
8	STP-1687-229	2' Top Blank / Stiffener, 1-11/16" Spiral Shogun
	STP-2125-229	2' Top Blank / Stiffener, 2-1/8" Spiral Shogun
9	STP-1687-013	3/8"-16 x 1" Bolt and Nut Set - For 1-11/16" & 2-1/8" Top Sub
	STP-1687-036	3/8"-16 x 1-1/4" Bolt and Nut Set - For 2-1/2" Top Sub
10	STP-1687-185	Tandem, 1-11/16" Spiral Shogun
	STP-2125-185	Tandem, 2-1/8" Spiral Shogun
11	STP-1687-208	1-11/16" Det. Cord Retainer - for blank intervals on strip
	STP-2125-208	2-1/8" & 2-1/2" Det. Cord Retainer - for blank intervals on strip
12	AES-AS60030	Magnetic Decentralizer, For 1-11/16" Spiral Shogun
	DEC-2125-000	Magnetic Decentralizer, For 2-1/8" & 2-1/2" Spiral Shogun
13	AES-AS50029	Adapter Cablehead to expendable
A	A578010	Det Cord, 80 Grain RDX-LS
	A571010	Det Cord, 80 Grain HMX
	A576010	Det Cord, 80 Grain HMX Teflon
C	STP-1687-401NTX	Charge, 1-11/16" HMX, Spiral Shogun NTX, SDP
	STP-1687-401NT	Charge, 1-11/16" HMX, Spiral Shogun NT, SDP
	STP-1687-401NB	Charge, 1-11/16" HMX, Spiral Shogun NT, BH
	STP-2125-401NTX	Charge, 2-1/8" HMX, Spiral Shogun NTX, SDP
	STP-2125-401NT	Charge, 2-1/8" HMX, Spiral Shogun NT, SDP
	STP-2125-401NB	Charge, 2-1/8" HMX, Spiral Shogun NT- BH
D	--	Resistorized Detonator (See Det. Ref. Section)
-	STP-1687-162	Alignment Tool Kit for NT Charge
-	STP-1687-164	1-11/16" Shogun Tightening Tool
-	STP-2125-164	2-1/8" Shogun Tightening Tool
-	MAN-STP1-001	Manual, Spiral Shogun Strip/Shogun Snake

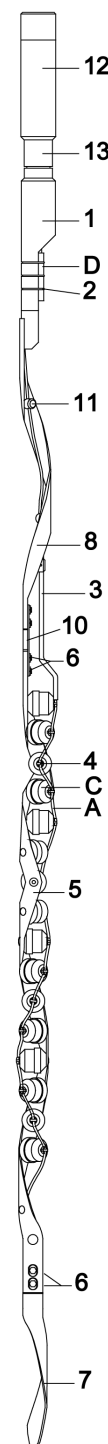

1.0 Pre-Assembly



Warning: *Explosives are destructive by nature! Do not attempt to disassemble or alter explosive products in any manner! Do not crush, hammer, pinch, impact, pull wires or abuse any explosive product!*



Warning: *Be sure to follow safe operating practices as found in API RP-67 in accordance with governmental regulations, company policies and manufacturer's recommendations!*



Caution: *At the Top Sub always use a Top Blank / Stiffener (item 8) to connect to the strip! On guns that use a Tandem, ensure that the top shot and the tandem shot are in-line!*



Note: *Before loading and testing, visually inspect the strip for any defects.*

2.0 Assembly

2.1 Screw the charge in the strip by hand until it seats against the strip. Be careful not to cross thread. Tighten by using the appropriate size Shogun Tightening Tool.



Caution: *Excessive force is not required to properly tighten the charge! Using excessive force could damage the threads of the charge or strip!*



Caution: *Never tighten by gripping the case! Tightening on the charge case could damage the O-ring which could cause the charge to leak!*

2.2 Align the detonating cord slot with the strip, by using the appropriate size Shogun Alignment Tool.

Shogun Spiral Strip/Shogun Snake



Caution: *Make sure that the case is turned clockwise as little as possible when aligning the det cord groove!*

2.3 Attach the det cord by inserting it into the charge case groove for the entire gun. Leave 8 in. (20 cm) of excess det cord on the bottom and enough det cord on the top to reach 5 in. (13 cm) past the top end of the spiral strip.

2.4 Attach the clip by placing one side in the cap groove, then snap in the opposite side by pressing the clip with the edge of a small screwdriver or small rod.

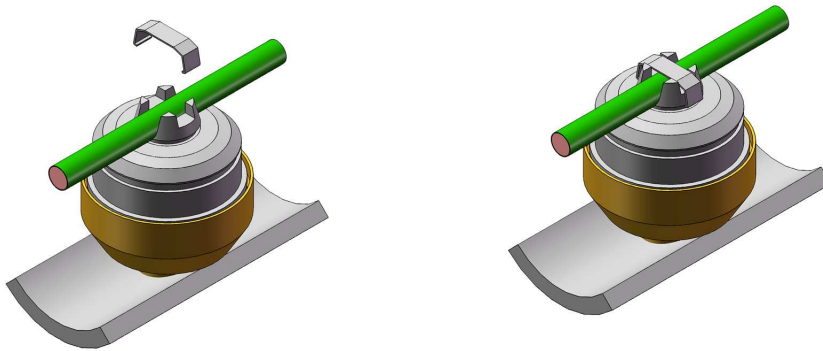

2.5 Assemble the Tandem as shown below.

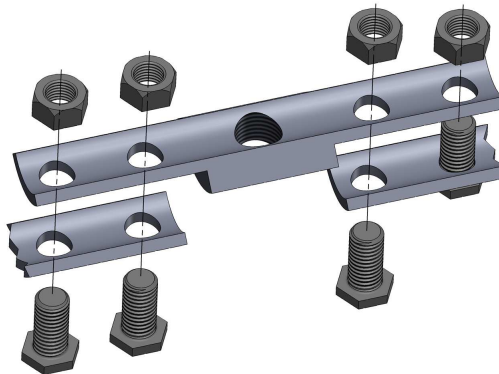

2.6 Attach additional charges and/or strips by repeating steps 2.1-2.5.

2.7 Attach the Guide Nose by using the Bolt and Nut Set. Use wire in the groove between the strip and Guide Nose to secure the end of the det cord after it has been ran through the charges or retainers.

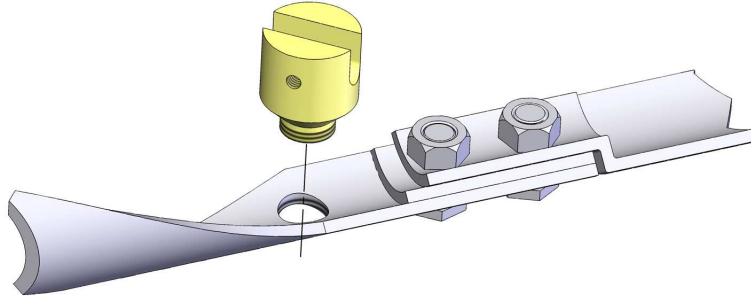

2.8 Attach the firing head to the CCL (in accordance with your company's policies and procedures) as shown below.

2.9 Check fire through the CCL and the Firing Head in accordance with your company's safety instructions. "See fire" don't depend an indication on a meter.

2.10 Place the detonator in a safety shield and then electrically attach the detonator to the firing head by attaching the red lead from the detonator to the hot lead from the firing head. Attach the blue lead (ground) to the ground lead provided.

2.11 Only after attaching the detonator electrically to the line, attach the detonator to the det cord by making a clean cut on the det cord (using Owen Super Cutters). Insert the det cord in the detonator and crimp (using Owen Super Crimpers).



Caution: *XHV Detonating Cord should not be used for exposed applications. Users should refer to the Detonating Cord selection chart to select a detonating cord rated for the intended application.*

2.12 The connection of the detonator and detonating cord must be sealed as well for an exposed well environment. Owen has developed and proven a best practice for sealing exposed detonator/detonating cord interface. Once the detonating cord has been crimped to the detonator;

A. While stretching, tightly wrap the 1st layer of Temp Tape (PUR-6100-006) starting 0.250 in. (.64 cm) below the crimp on the Detonator Body and ending 0.250 in. (.64 cm) past the crimp on the det cord. Without cutting the tape, tightly

wrap (while stretching) a 2nd layer of tape, following the above process, but in reverse. Now with the tape uncut, stretch and tightly wrap 2 more layers, by following the methods of the first 2 layers.

B. Starting 0.750 in. (1.9 cm) past one end of the wrapped Temp Tape, begin tightly wrapping (while stretching) the Mocap Tape (PUR-6100-011) over the Temp Tape, until it extends 0.750 in. (1.9 cm) past the Temp Tape. Without cutting the tape, tightly wrap (while stretching) another layer of tape, following the above process, but in reverse.

C. While stretching, tightly wrap 1 layer of Temp Tape, starting 0.500 in. (1.27) past one end of the Mocap Tape, then over the Mocap Tape until it extends 0.500 in. (1.27 cm) past the end of the Mocap Tape. Now, tightly wrap (while stretching) another layer of tape, following the above process, but in reverse.



Note: *It is essential that when wrapping the tape, that you make sure to overlap the wraps of each layer. This detonator was designed and qualified using the specified tape types and sealing method. All Quality Control (QC) tests are performed using these same procedures.*

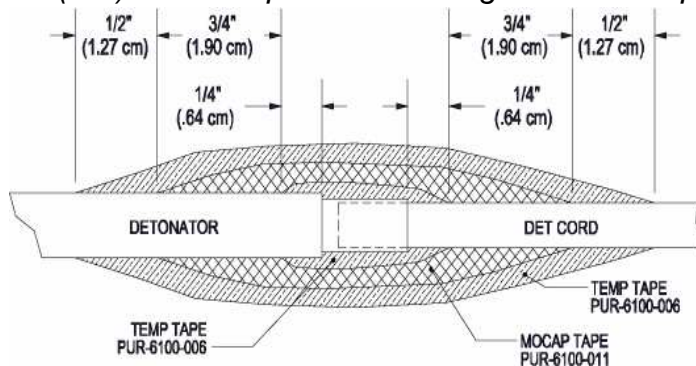

Complete the mechanical assembly of the device and tool assembly by attaching the detonator to the toolstring, taking care not to force, pinch, crush, or impact the explosive components or wiring.

2.13 Secure the detonator to the Firing Head by using Seizing Wire/Cord in the grooves provided in the Firing Head.

3.0 Running Guidelines



Caution: *Do not run the gun in dry wells or where gas could be present! The strip could be severely bent or severed!*



Note: *Always decentralize the gun system to be shot with all tandem charges and the top shot in contact with the casing wall. This will minimize distortion of the strip.*



Note: *Use plastic Det Cord Retainers if you are running blank sections or running in zones shorter than the carrier.*

3.1 Always run a gauge through the tubing before running any gun. On this run any correlating logs necessary can be done which saves time on bottom, especially in cases where high temperature and pressure exists.

3.2 Slowly insert the gun in the lubricator being careful not to bump the back edge of the charges. This could knock a charge loose and cause it to hang the gun in the tubing. Never try to raise the gun without using the lubricator. Doing so could cause the gun to be bent and cause a misrun or a fishing job. A charge could come out of the bent carrier strip.

3.3 The gun can be lowered at any reasonable speed except when lowering through some trouble spots, seating nipples, packers, etc....

3.4 When collars have been checked and the gun is in the zone, gradually raise the firing power to a maximum of one amp or until the gun fires.

3.5 After firing, the gun is raised to the surface by slowly pulling the gun through the end of the tubing, seating nipple, packer etc., then at any reasonable speed to the surface. If the gun strip was bent as result of the detonation you will notice a difference in weight entering the tubing. To date no pull greater than 250 lbs has been required to re-enter the tubing.

