



Segmented Casing Cutters for 8.625-13.375 inch Casing

MAN-REC-SGC (R02)

Owen Oil Tools LP

12001 CR 1000

Godley, Texas, 76044, USA

Phone: +1 (817) 551-0540

Fax: +1 (817) 551-1674

www.corelab.com/owen

Warning: Use of Owen equipment contrary to manufacturer's specifications or operating instructions may result in property damage, serious injury or fatality. If you are not trained in the handling and use of explosive devices, do not attempt to use or assemble any Owen perforating systems or Owen firing devices.

This technology is regulated by and, if exported, was exported from the United States in accordance with the Export Administration Regulations (EAR). Diversion contrary to U.S. law is prohibited. Export and/or re-export of this technology may require issuance of a license by the Bureau of Industry and Security (BIS), U.S. Department of Commerce. Consult the BIS, the EAR, and/or Owen Compliance Services, Inc. to determine licensing requirements for export or re-export of this technology.

This document contains Confidential Information of Owen Oil Tools LP (Owen) and is furnished to the customer for information purposes only. This document must not be reproduced in any way whatsoever, in part or in whole, or distributed outside the customer organization, without first obtaining the express written authorization of Owen. This document is the property of Owen and returnable upon request of Owen.

© 2009 Owen Oil Tools



Overview

Description

Segmented Casing Cutters are designed for use in Pipe Recovery Operations. The cutter is shipped disassembled for easy transportation and can be assembled for use on location.

Operation

Segmented Casing Cutters provide a quick and effective solutions to sever drill pipe and casing. These Cutters utilize unique manufacturing and packaging processes to allow easy shipment and fast delivery to the customer.

Segmented Casing Cutters should be used when drill pipe and/or casing becomes stuck in the well or during plug and abandonment operations. The cutter with the largest possible diameter capable of running in the well should be chosen to achieve maximum performance. A gauge run is recommended prior to running the tool to insure the cutter can get to proper depth. This will prevent any safety concerns like sticking a live cutter in the well or spudding with explosive tools. Owen's Cutters are to be shot in the tubular above the stuck point, but not at the collar. To maintain the maximum allowable performance from the cutter, it should be centralized. A de-centralized cutter may result in a partial cut and/or damage to the casing. It is also recommended that tension be applied to the casing prior to detonation of the Casing Cutter to assist in the removal of stuck tubulars.

Segmented Casing Cutters utilize explosive technology and are designed to explosively sever tubular members when initiated by an Owen's Resistorized Bridge™ Detonator. Owen's electrical detonators adhere to API RP-67 specifications. All safety rules and regulations should be strictly followed when storing, handling, assembling, and using these cutters and/or detonators. Safety precautions should be taken in accordance with your company's safety policies, governmental regulations, and the American Petroleum Institute Recommended Practice 67 (API RP-67).

Cutters come standard with RDX explosive powder rated to 325° F (163° C) for 1 hour. Cutters are also available with HMX [400° (204° C) - 1 hour] or HNS [500° F (260° C) - 1 hour] by special order.

Segmented Casing Cutters

Specifications and Schematics

Item	Description	Part Number
1	Adapter Housing - Steel, open bore	CUT-0100-087
	Adapter Housing - 3/4" pipe	CUT-0100-109
	Adapter Housing - open bore	CUT-0100-079
	Adapter Housing - JRC style with electrical contacts	CUT-0100-078
2	O-ring, Size -214 Viton	000-V569-214
3	Detonator Adapter	CUT-0100-082
4	O-ring, Size -208 Viton	000-V569-208
5	Splice Boot	PUR-0210-001
D	Cutter Detonator - Booted det with lead wires	DET-3050-009L
	Cutter Detonator - Booted det with spring contact	DET-3050-009E
Segmented Casing Cutter Assembly		7.250" OD 8.250" OD
	325F	CUT-7250-031 CUT-8250-031
	400F	CUT-7250-032 CUT-8250-032
	500F	CUT-7250-033 CUT-8250-033
Segmented Casing Cutter Assembly		9.500" OD 12.000" OD
	325F	CUT-9500-031 CUT-1200-031
	400F	CUT-9500-032 CUT-1200-032
	500F	CUT-9500-033 CUT-1200-033

- Items 1, 2, 5 and detonator must be ordered separately from cutter assembly.
- Items 3 and 4 are included in the assembly.
- Alternate arming assembly available using JRC style extension adapter with button contacts, CUT-0100-078, and detonator with spring contacts, DET-3050-009E.

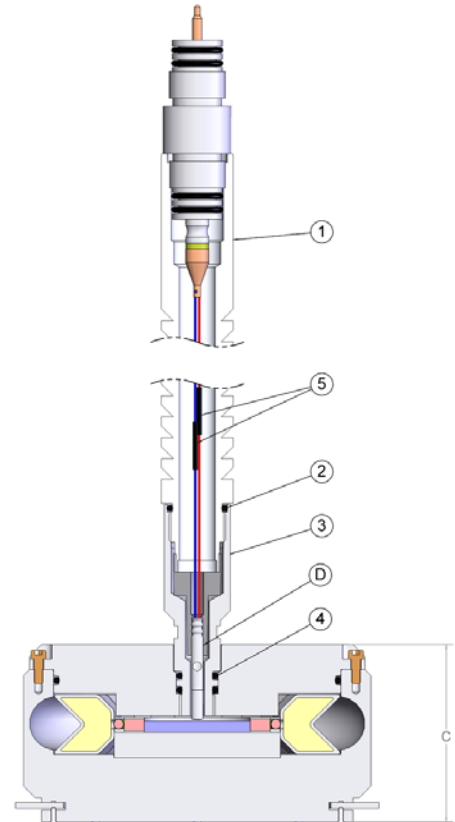

Running Diameter	7.250 in.	8.250 in.	9.500 in.	12.000 in.
Temperature Rating (F)	325	325	325	325
	400	400	400	400
	500	500	500	500
Pressure Rating (psi)	9,000	10,000	10,000	4,000
Explosive Weight (g)	333	402	462	650
Recommended Application	8-5/8" Casing 24# - 77#	9-5/8" Casing 32.75# - 55#	11-3/4" Casing 42# - 60#	13-3/8" Casing 48# - 77#

1.0 Assembly of Segmented Casing Cutters

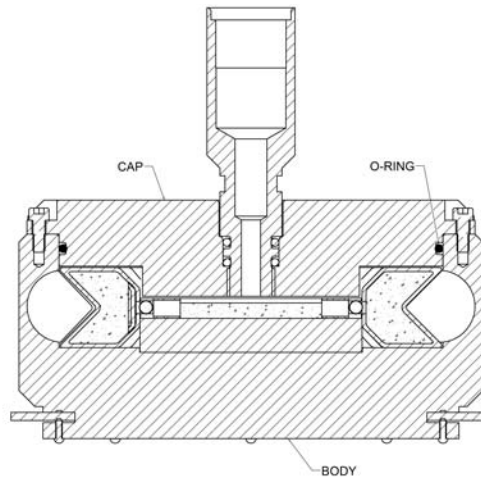

1.1 Remove the O-ring from its package and visually inspect it for cuts or cracks. Lightly lubricate O-ring with grease and install the O-ring onto the Cap.

1.2 Place the Body onto a flat surface with the open end upward for assembly, then unpack the Pellets, the Ignition Cartridge and all other explosive components.

1.3 Cut the 80 grain Det cord to the appropriate length shown below. The figures below, are for det cord cut under ideal conditions.

Casing Cutter	Length of detonating cord
7.250 in.	13 in. / 33 cm
8.250 in.	14.5 in. / 36.8 cm
9.500 in.	19 in. / 48.3 cm
12.000 in.	17.5 in. / 44.5 cm

1.4 Wrap the Detonating Cord around the outside groove of the Cartridge Holder and push it into the groove until it is fully seated. Make sure the ends of the Det Cord do not meet at the face-cut groove. Place the Cartridge Holder into the center of the Cutter Body.

1.5 Starting with the #1 segment, place the Segments into the Cutter Body. Make sure the Segments rest flat in the bottom of the body. The Segments have been tested for proper fit and should be kept together as a set.

1.6 Insert the Cartridge tubes into the slots provided. Make sure that the end of the tube is flush with the Det Cord.

Segmented Casing Cutters

1.7 Insert the Ignition Cartridge (1/4 in. explosive disc) into the center of the Cartridge Holder.

1.8 Install the Cap onto the Body and secure in place with the Cap Screws.

2.0 Arming Segmented Casing Cutters



Warning: Always follow API RP-67 guidelines when arming electrical detonators!

2.1 Remove the detonator from its package, then insert the detonator into a safety shield.

2.2 Measure the resistance of the detonator between the two lead wires with a blaster's multimeter. The detonator should read 51 Ohms \pm 5 Ohms.

2.3 Remove the O-rings from their package and visually inspect them for cuts or cracks. Lightly lubricate O-rings with grease. Install the 214 O-ring onto the Extension Adapter, and the 208 O-rings onto the detonator adapter.

2.4 Insert the detonator leadwires through the hole in the Extension Adapter.

2.5 Electrically connect the detonator leadwires to the wireline or toolstring, then mechanically connect the Extension Adapter to the wireline toolstring.

2.6 Insure the wireline is shunted through the shooting panel.

2.7 Remove the detonator from the safety shield and install the booted portion of the detonator over the end of the Extension Adapter.

2.8 Insert the detonator into the detonator Adapter and thread it onto the Extension Adapter and toolstring.

2.9 Thread the Cutter onto the detonator Adapter. The tool is armed and ready to run in hole.