



Extended Hardware Coil Tubing Transfer System

TC-039-1688-100

MAN-TC-039-100

Owen Oil Tools LP

12001 CR 1000

Godley, Texas, 76044, USA

Phone: +1 (817) 551-0540

Fax: +1 (817) 551-1674

www.corelab.com/owen

Warning: Use of Owen equipment contrary to manufacturer's specifications or operating instructions may result in property damage, serious injury or fatality. If you are not trained in the handling and use of explosive devices, do not attempt to use or assemble any Owen perforating systems or Owen firing devices.

Owen Oil Tools pre-assembles its tools as per the field operating manual. It is the responsibility of the purchaser to insure that this tool is assembled as required, prior to use.

This technology is regulated by and, if exported, was exported from the United States in accordance with the Export Administration Regulations (EAR). Diversion contrary to U.S. law is prohibited. Export and/or re-export of this technology may require issuance of a license by the Bureau of Industry and Security (BIS), U.S. Department of Commerce. Consult the BIS, the EAR, and/or Owen Compliance Services, Inc. to determine licensing requirements for export or re-export of this technology.

This document contains Confidential Information of Owen Oil Tools LP (Owen) and is furnished to the customer for information purposes only. This document must not be reproduced in any way whatsoever, in part or in whole, or distributed outside the customer organization, without first obtaining the express written authorization of Owen. This document is the property of Owen and returnable upon request of Owen.

© 2010 Owen Oil Tools

Extended Hardware Coil Tubing Transfer System



BOM and Schematic

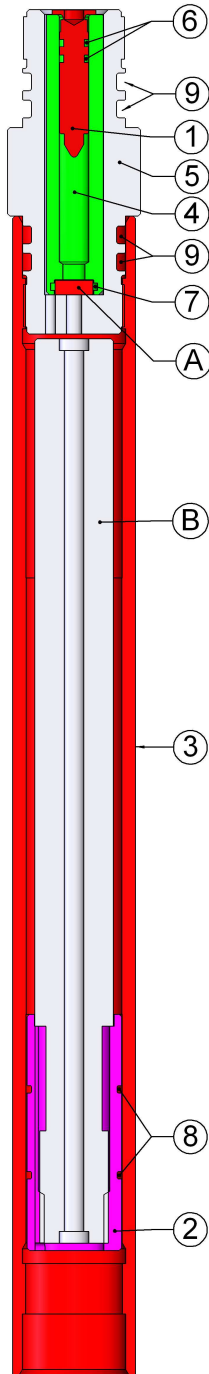

Item	Part Number	Qty	Description
--	TC-039-1688-100	--	Extended Hardware , CT Transfer, 1-11/16
1*	TC-044-0003-000	1	Firing Pin, CT Transfer
2*	TC-039-0004-000	1	Support Block, 6-Min TD, 1-11/16
3	TC-039-0005-000	1	Housing, 6-Min TD, 1-11/16
4*	TC-039-0002-100	1	Sleeve, firing Pin, Ext.
5	TC-039-0003-100	1	Sub Connecting, Ext. Hardware
6*	OOO-N569-010	2	O-ring, N-90
7*	OOO-N569-014	1	O-ring, N-90
8*	OOO-N569-023	2	O-ring, N-90
9*	OOO-N569-215	4	O-ring, N-90
A	2-350220-1	1	Igniter (sold separately)
B	51-8200-4	1	6-Minute TD Fuse (sold separately)
--	TC-039-1688-199	--	Redress Kit for TC-039-1688-100
--	TC-039-1688-399	--	Redress Kit, HT for TC-039-1688-100
--	MAN-TC-039-100	--	Manual

* Denotes parts that are in the redress kit

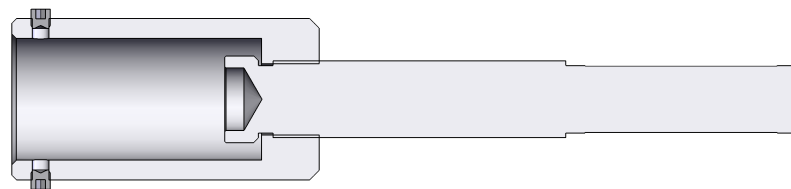

Installation and Removal Tool
TC-039-0010-000

Extended Hardware Coil Tubing Transfer System





Warning: *The assembly of this tool requires the use of an Explosive Device and all safety precautions must be adhered to and observed! Only personnel trained in explosive handling procedures should be allowed to arm this firing head assembly!*



Note: *Check all items against the parts list to be sure you have the correct parts and quantities.*



Note: *Check for any damage to the parts which would prevent the part from being assembled correctly, easily and safely.*

1.0 Assembly

1.1 Install the O-rings (items 6) onto the firing Pin (item 1). Install O-ring (item 7) into the groove in the bottom of the Firing Pin Housing (item 4). Apply grease to the o-ring on the firing pin and insert into the firing pin housing.

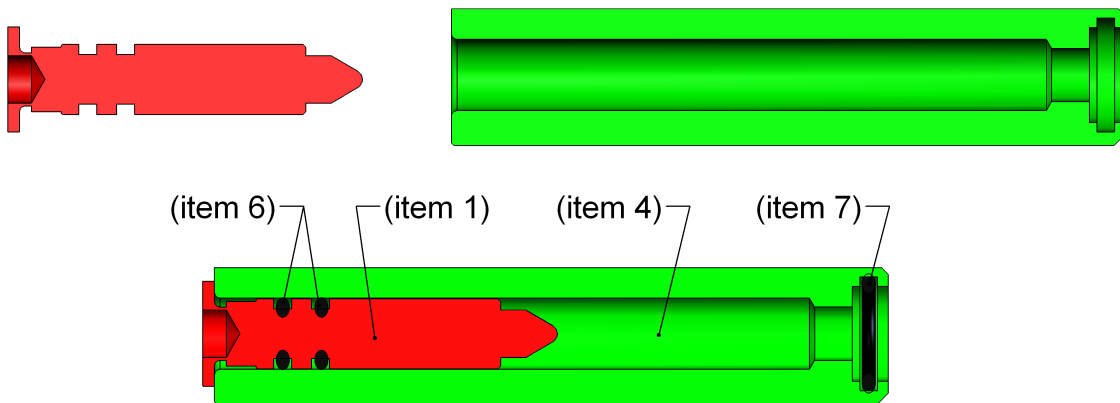

Extended Hardware Coil Tubing Transfer System



1.2 Install the O-rings (item 9) onto the Connecting Sub (item 5). Remove the Igniter (item A) from its shipping package. The igniter will have the initials FP on one side and the other side will be colored RED. Insert the igniter into the recess of the firing pin housing with the FP side facing the firing pin and the RED side facing outward.

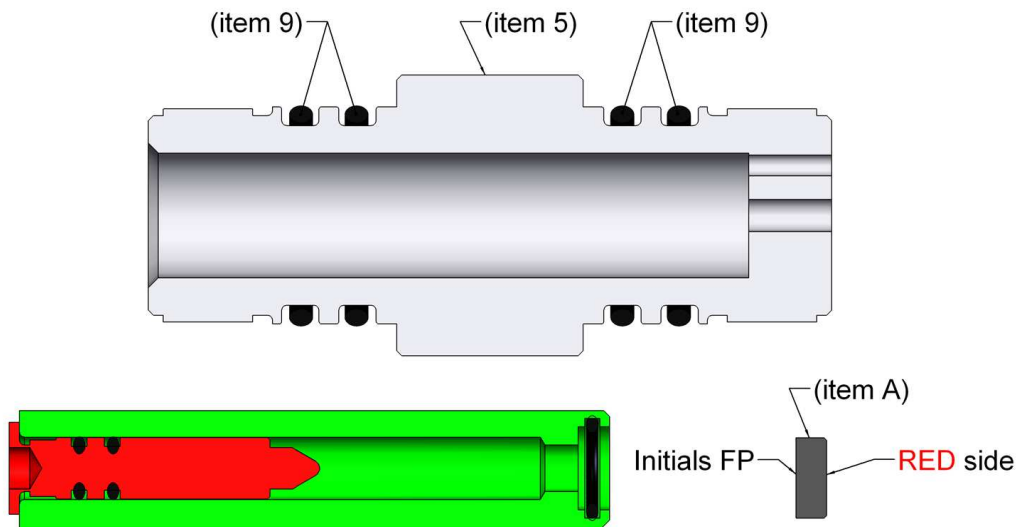

1.3 With the igniter inserted in the bottom of the firing pin housing, slide this small assembly all the way into the connecting sub. Be aware that the igniter stays in the housing. The firing pin should be near flush with the top of the connecting subs face. Look to see if RED is visible through the center hole on the bottom of the sub. Set aside this assembly in a safe location.

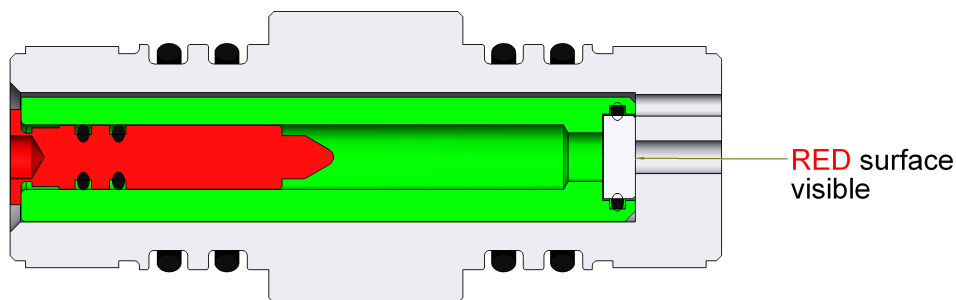

1.4 Install the O-rings (item 8) onto the Fuse Support Block (item 2).

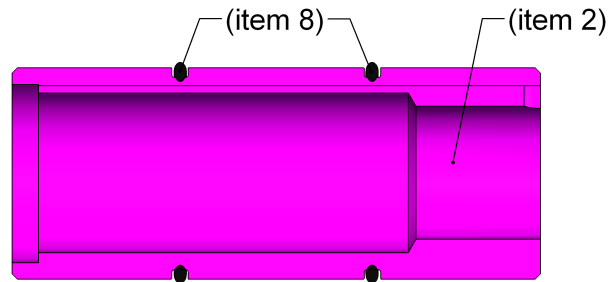

1.5 Remove the 6-Minute TD Fuse (item B) from its shipping package. Remove the safety shield and thread the fuse into the support block until the two parts shoulder up.

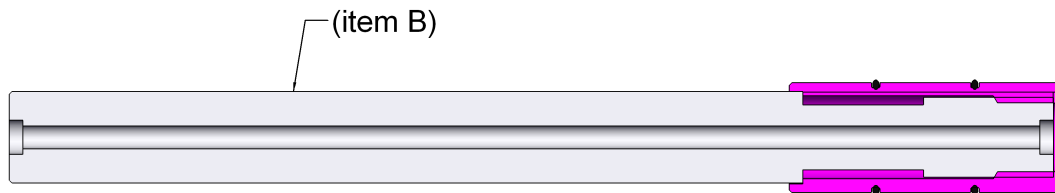

Warning: Use extreme caution when handling the explosive Time Delay Fuse.

Extended Hardware Coil Tubing Transfer System



1.6 Apply some grease to the o-rings on the fuse support block and insert into Outer Fuse Housing (item 3) up to the first o-ring. Use the Installation Tool (TC-039-0010-000) to help push the fuse assembly into the housing. Back off the pressing rod up into the outer tool housing, slide over the end of the housing, and tighten set screws onto fuse housing. Gently thread in pressing rod which in turn will push fuse assembly into fuse housing. Push in until the top of the fuse is near the thread relief. When done, loosen set screws and remove tool.

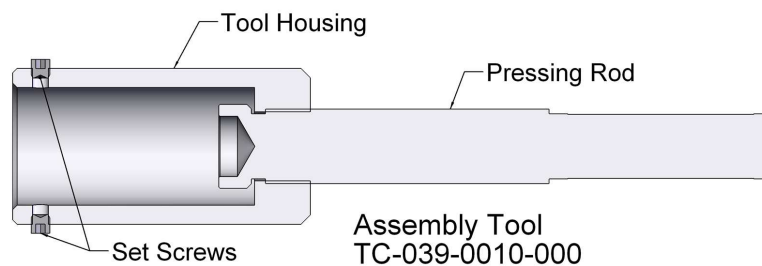
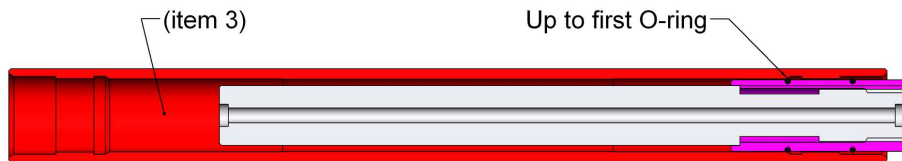

1.7 Apply grease to the o-rings and threads of the top gun sub onto which you will be putting the time delay fuse. Thread the fuse and it's housing assembly onto the top gun sub, tighten.

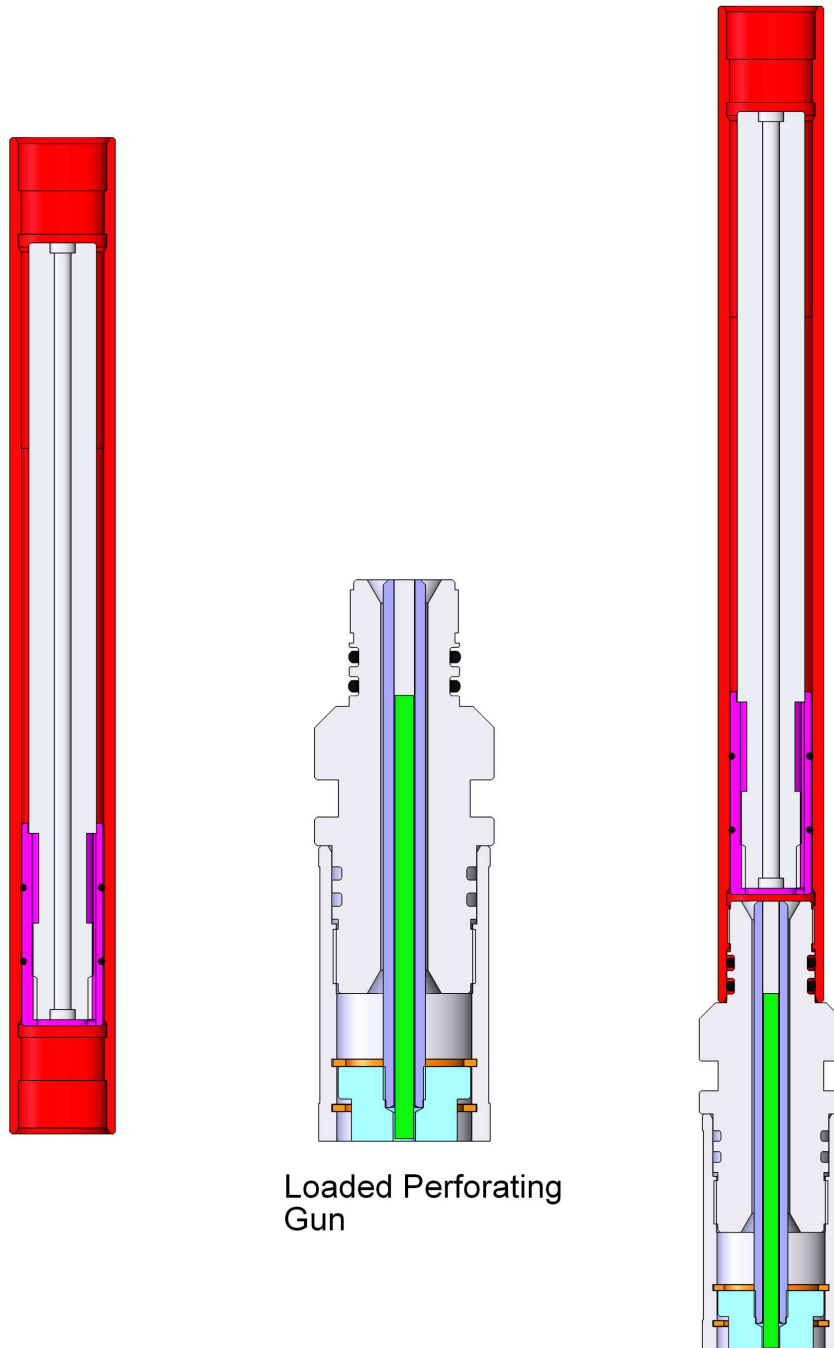

Loaded Perforating
Gun

Extended Hardware Coil Tubing Transfer System



1.8 Apply some grease to the o-rings and threads of the connecting sub and thread into top of the time delay housing, tighten. This setup is for extended burn time to the perforating system. Now more extended time delay systems can be added to this or it's ready to be connected to the single fuse system that will connect to the bottom of the donor gun.

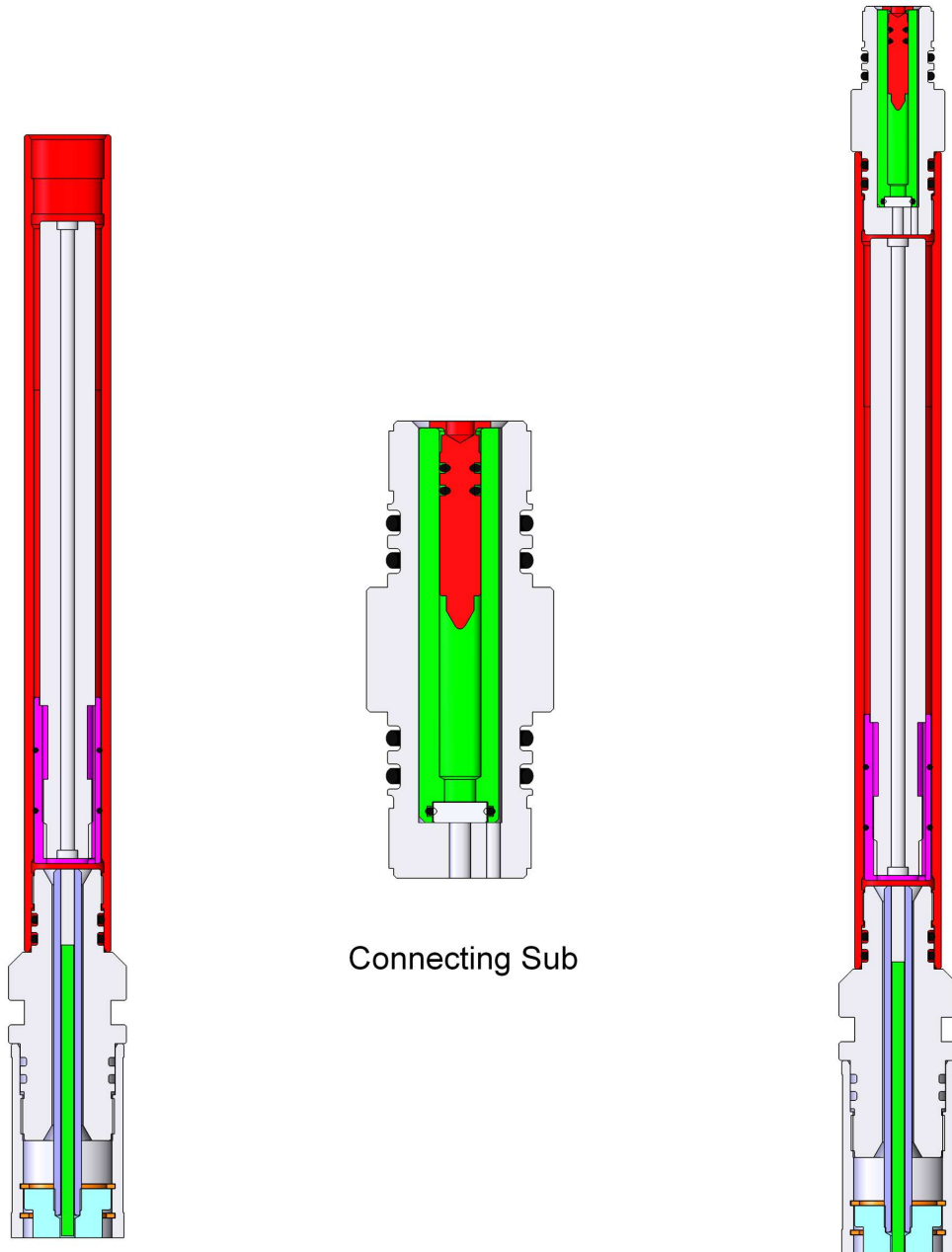

1.9 Apply some grease to the o-rings and threads of the connecting sub of the extended time housing and thread into the bottom of the single fuse housing that will be connected to the bottom of the Donor Gun, tighten.

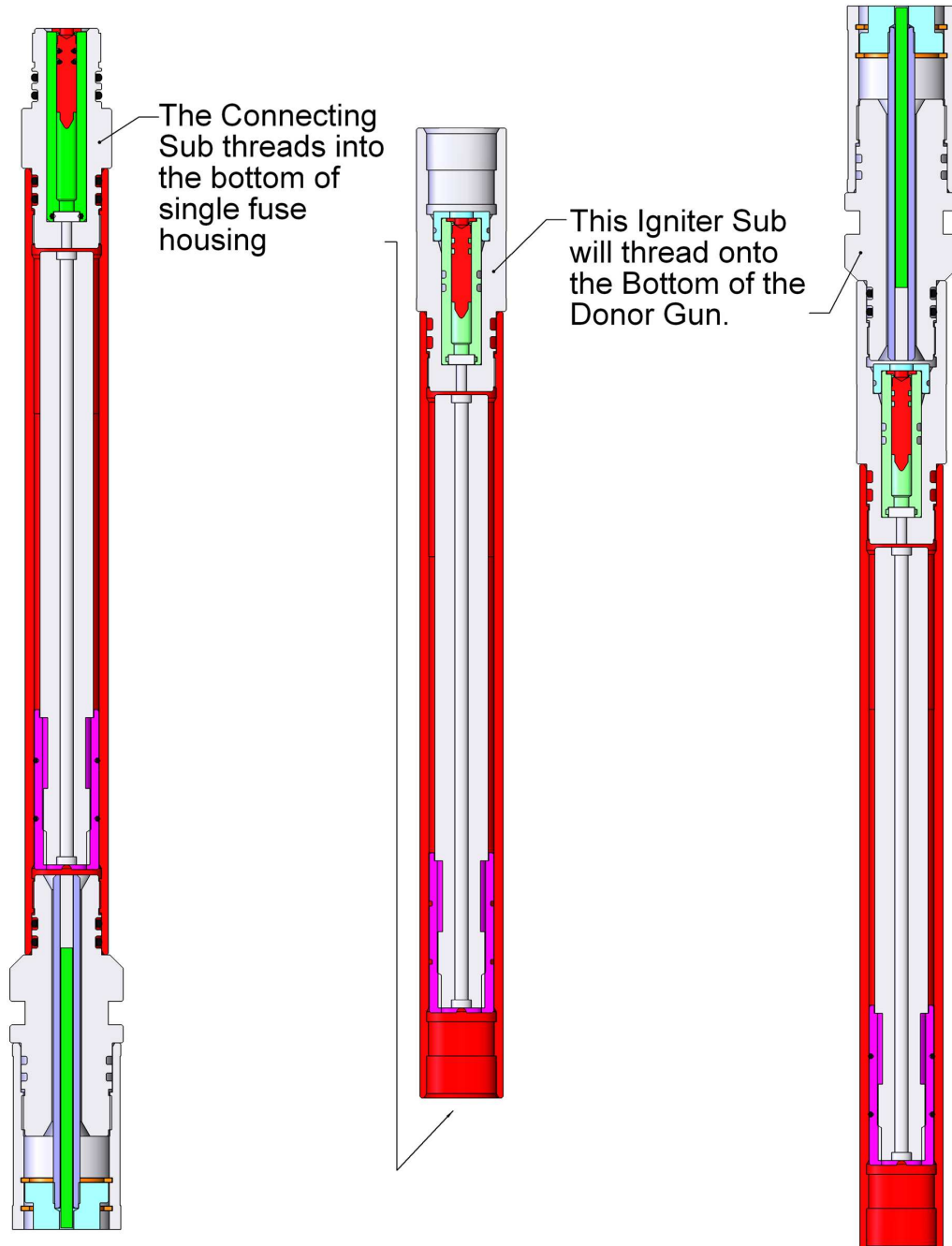

Time vs Temperature Chart

