



Packer By-Pass System 7 inch Packer w/ 2-7/8 inch EUE

TC-180-2875-000

MAN-TC-180-2875-000 (R01)

Owen Oil Tools

12001 CR 1000

Godley, Texas, 76044, USA

Phone: +1 (817) 551-0540

Fax: +1 (817) 551-1674

www.corelab.com/owen

Warning: Use of Owen equipment contrary to manufacturer's specifications or operating instructions may result in property damage, serious injury or fatality. If you are not trained in the handling and use of explosive devices, do not attempt to use or assemble any Owen perforating systems or Owen firing devices.

Owen Oil Tools pre-assembles its tools as per the field operating manual. It is the responsibility of the purchaser to insure that this tool is assembled as required, prior to use.

This technology is regulated by and, if exported, was exported from the United States in accordance with the Export Administration Regulations (EAR). Diversion contrary to U.S. law is prohibited. Export and/or re-export of this technology may require issuance of a license by the Bureau of Industry and Security (BIS), U.S. Department of Commerce. Consult the BIS, the EAR, and/or Owen Compliance Services, Inc. to determine licensing requirements for export or re-export of this technology.

This document contains Confidential Information of Owen Oil Tools LP (Owen) and is furnished to the customer for information purposes only. This document must not be reproduced in any way whatsoever, in part or in whole, or distributed outside the customer organization, without first obtaining the express written authorization of Owen. This document is the property of Owen and returnable upon request of Owen.

© 2008 Owen Oil Tools

Packer By-pass System 7 inch
Packer w/ 2-7/8 inch EUE



Packer By-Pass System

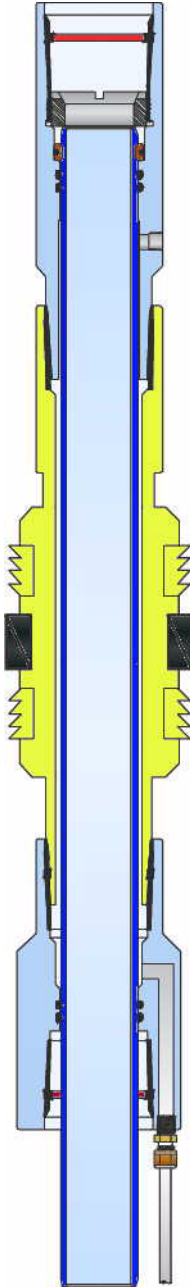

Description

The Packer By Pass System is used with Owen Redundant Annulus Pressure Firing System or Owen Differential Firing Head to allow annulus pressure above the packer to be routed below the packer.

Features and Benefits

- Works with full bore packers
- Open bore by-pass tube
- Adjustable length
- Isolates clean fluid to the firing head using a “water leg” technique

Specifications

TC-180-2875-000		
Max. Hydrostatic	20,000 psi	137.9 MPa
Max. Differential	7,500 psi	51.7MPa
Min. Packer I.D.	2.313 in	58.8 mm
I.D. on By-Pass	1.875 in	47.6 mm



BOM and Schematic

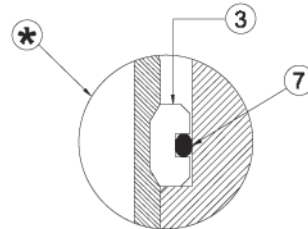
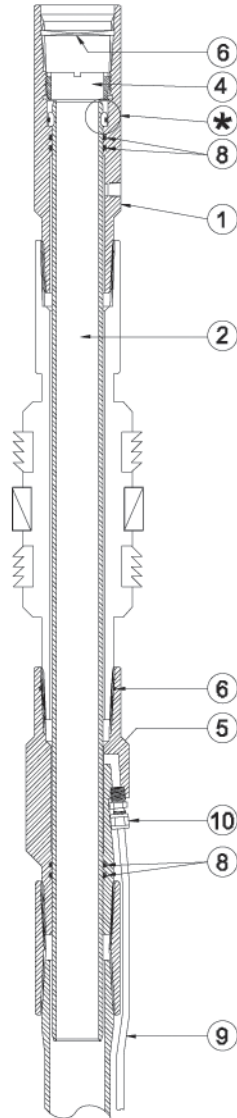

Item	Part No.	Qty	Description
--	TC-180-2875-000	--	Packer By-Pass Assy., 2-7/8" EUE
1	TC-180-0005-000	1	Pressure Port Sub
2	TC-180-0006-000	1	By-pass Tube, 2-7/8"
3	TC-180-0007-000	1	Securing Ring, 2-7/8"
4	TC-180-0008-000	1	Locking Ring, 2-7/8"
5	TC-180-0009-000	1	Bottom Sealing Sub, 2-7/8"
6	MI-305-2875-000	3	API Seal Ring, 2-7/8
7	OOO-N569-142	1	O-Ring N-90
8	OOO-N569-228	4	O-Ring N-90
9	TC-001-0004-000	--	Steel Tubing random length (not included)
10	TC-001-0005-000	--	Tubing Fitting (not included)
--	TC-090-0007-000	--	Lock Ring Tool
--	TC-180-2875-099	--	Redress Kit 7" & Larger PBP
--	MAN-TC-180-2875-000	--	Assembly Manual

Item	Part No.	Qty	Description
--	TC-180-2875-099	--	Redress Kit 7" & Larger PBP
6	MI-305-2875-000	3	API Seal Ring, 2-7/8
7	OOO-N569-142	1	O-Ring N-90
8	OOO-N569-228	4	O-Ring N-90





Warning: The assembly of this tool requires the handling of an Explosive Device and all safety precautions must be adhered to and observed!



Note: Check all items against the parts list to be sure of having the correct parts and quantities.



Note: Check for any damage to the parts which would prevent the part from being assembled correctly, easily and safely.

1.0 Assembly

1.1 Install O-rings (item #8) and API Seal Rings (item #6) in the Pressure Port Sub (item #1) and the Bottom Seal Sub (item #5). Apply grease to the O-rings on the inside of the subs for assembly of the by-pass system.

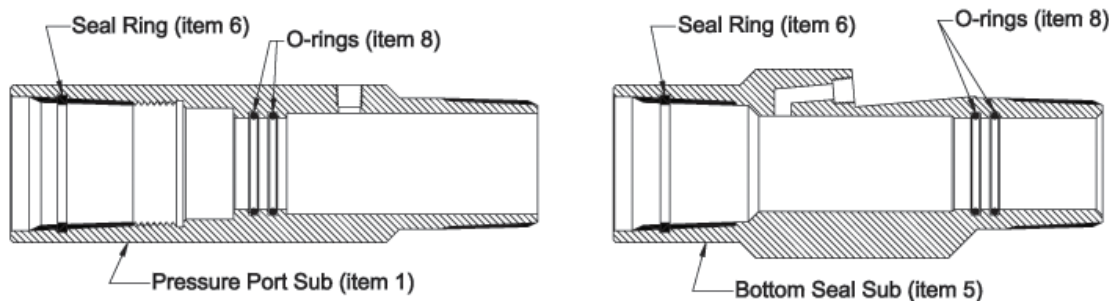

1.2 Apply a thin layer of grease to grooved end of the By-Pass Tube (item #2). Insert the groove end of the tube through the pin side of the Pressure Port Sub using caution not to cause damage to the O-rings. Insert the tube until approximately 2 to 3 inches protrude

Packer By-Pass System 7 inch Packer w/ 2-3/8 inch EUE



out the top of the sub. Install the Securing Ring (item #3) in the tube groove and secure in place with the O-ring (item #7) in the groove machined on the outside of the ring.

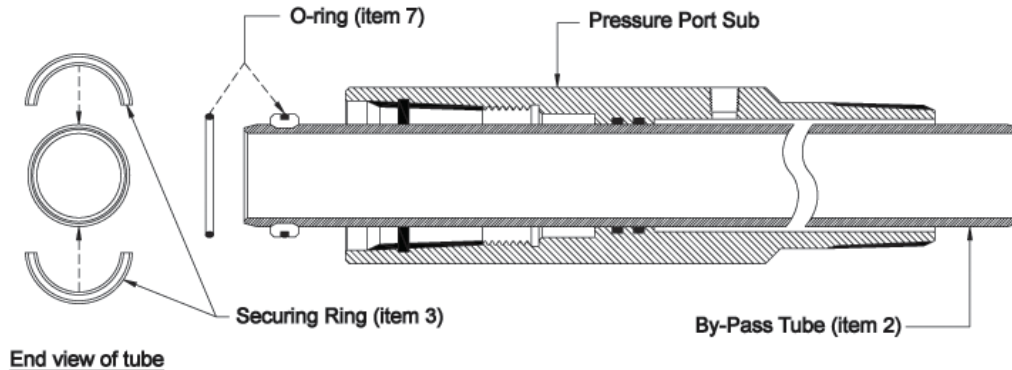

1.3 Slide the tube back through the Pressure Port Sub until the Securing Ring is seated in the machined recess of the sub. Secure in place with the Locking Ring (item #4) using the Lock Ring wrench (TC-090-0006-000). Be sure the Locking Ring is threaded in until it is bottomed out, so not to interfere with the 2-3/8 EUE thread make-up.

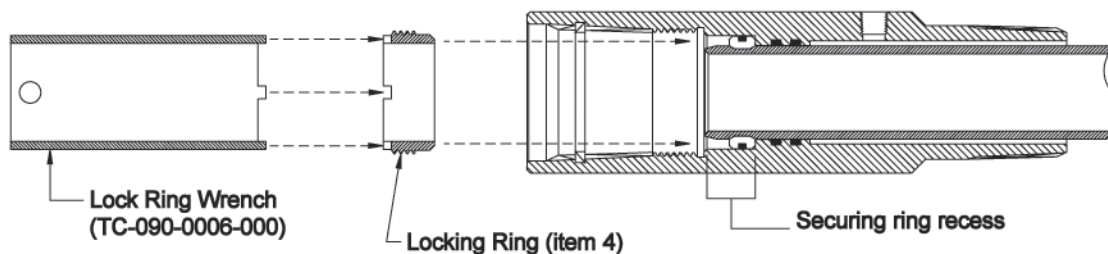

1.4 Insert the pressure port sub and tube assembly through the downhole packer to be used.



Caution: When inserting, support the assembly so as the tubes surfaces do not scrap on or against the inner wall of the packer!

Apply grease to the pin end of the pressure port sub and thread hand tight into the packer.

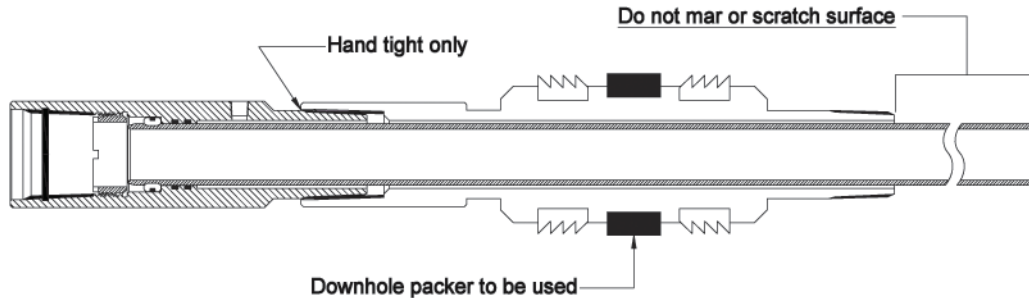

1.5 Apply a thin layer of grease to the surface of the tube which is protruding out the bottom of the packer. Slide the Bottom Sealing Sub over the tube, using caution not to cause damage to the O-rings in the sub. Apply grease to the threads of the pin end of the packer, thread the Bottom Sealing Sub onto the packer and tighten. After tightening the Bottom Sealing Sub, tighten the Pressure Port Sub at the top of the packer.

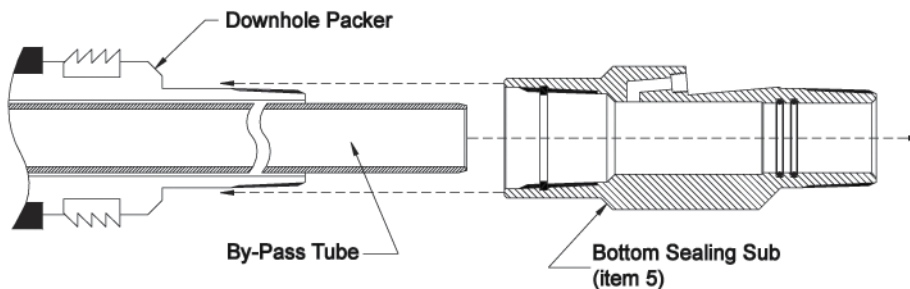

Note: It is good practice to recheck the locking ring in case it loosened during the sub tightening process.

Packer By-Pass System 7 inch Packer w/ 2-3/8 inch EUE



The Packer By-Pass Assembly is now complete. The tubing fitting can be installed at this time or at location.

