



NT Segmented Casing Cutters for 4.500-in - 7.625-in Casing

MAN-REC-SCC (R05)

Owen Oil Tools

12001 CR 1000

Godley, Texas, 76044, USA

Phone: +1 (817) 551-0540

Fax: +1 (817) 551-1674

www.corelab.com/owen

Warning: Use of Owen equipment contrary to manufacturer's specifications or operating instructions may result in property damage, serious injury or fatality. If you are not trained in the handling and use of explosive devices, do not attempt to use or assemble any Owen perforating systems or Owen firing devices.

This technology is regulated by and, if exported, was exported from the United States in accordance with the Export Administration Regulations (EAR). Diversion contrary to U.S. law is prohibited. Export and/or re-export of this technology may require issuance of a license by the Bureau of Industry and Security (BIS), U.S. Department of Commerce. Consult the BIS, the EAR, and/or Owen Compliance Services, Inc. to determine licensing requirements for export or re-export of this technology.

This document contains Confidential Information of Owen Oil Tools LP (Owen) and is furnished to the customer for information purposes only. This document must not be reproduced in any way whatsoever, in part or in whole, or distributed outside the customer organization, without first obtaining the express written authorization of Owen. This document is the property of Owen and returnable upon request of Owen.

© 2007 Owen Oil Tools

NT Segmented Casing Cutters for 4.500-in - 7.625-in Casing





Overview

Description

NT Segmented Casing Cutters are designed for use in Pipe Recovery Operations. The cutter is shipped disassembled for easy transportation and can be assembled for use on location.

Operation

NT Segmented Casing Cutters provide a quick and effective solutions to sever drill pipe and casing. These NT Cutters utilize unique manufacturing and packaging processes to allow easy shipment and fast delivery to the customer.

NT Segmented Casing Cutters should be used when drill pipe and/or casing becomes stuck in the well or during plug and abandonment operations. The cutter with the largest possible diameter capable of running in the well should be chosen to achieve maximum performance. A gauge run is recommended prior to running the tool to insure the cutter can get to proper depth. This will prevent any safety concerns like sticking a live cutter in the well or spudding with explosive tools. Owen's NT Cutters are to be shot in the tubular above the stuck point, but not at the collar. To maintain the maximum allowable performance from the cutter, it should be centralized. A de-centralized cutter may result in a partial cut and/or damage to the casing. It is also recommended that tension be applied to the tubing prior to detonation of the Tubing Cutter to assist in the removal of stuck tubulars.

NT Segmented Casing Cutters utilize explosive technology and are designed to explosively sever tubular members when initiated by an Owen's Resistorized Bridge™ Detonator. Owen's electrical detonators adhere to API RP-67 specifications. All safety rules and regulations should be strictly followed when storing, handling, assembling, and using these cutters and/or detonators. Safety precautions should be taken in accordance with your company's safety policies, governmental regulations, and the American Petroleum Institute Recommended Practice 67 (API RP-67).

NT Cutters come standard with HMX explosive powder rated to 400° F (204° C) for 1 hour. Cutters are also available with HNS [500° F (260° C) - 1 hour] by special order.

NT Segmented Casing Cutters for 4.500-in - 7.625-in Casing



Specifications and Schematics

Item	Description	Part Number
1	Steel Extension Adapter	CUT-0100-087
	Aluminum Extension Adapter	CUT-0100-079
2	O-ring, Size -214	OOO-V569-214
3	Detonator Adapter	CUT-0100-082
4	O-ring, Size -208	OOO-V569-208
5	Splice Boot	PUR-0210-001
D	Tubing Cutter Detonator	DET-3050-009L
C	3 7/16" NT Casing Cutter	CUT-3437-062NT
	3 5/8" NT Casing Cutter	CUT-3625-062NT
	3 13/16" NT Casing Cutter	CUT-3812-062NT
	4 1/2" NT Casing Cutter	CUT-4500-062NT
	4 1/2" NT Casing Cutter	CUT-4750-062NT
	5 1/2" NT Casing Cutter	CUT-5500-062NT
	5 3/4" NT Casing Cutter	CUT-5750-062NT
	6 3/8" NT Casing Cutter	CUT-6375-062NT

- Items 1, 2, 5 and detonator must be ordered separately from cutter assembly.
- Items 3 and 4 are included in the assembly.
- HNS Cutters are available by special order. Parts should be ordered by replacing the 062NT with 063NT, for example CUT-XXXX-063NT.
- Alternate arming assembly available using JRC style extension adapter with button contacts, CUT-0100-078, and detonator with spring contacts, DET-3050-009E.

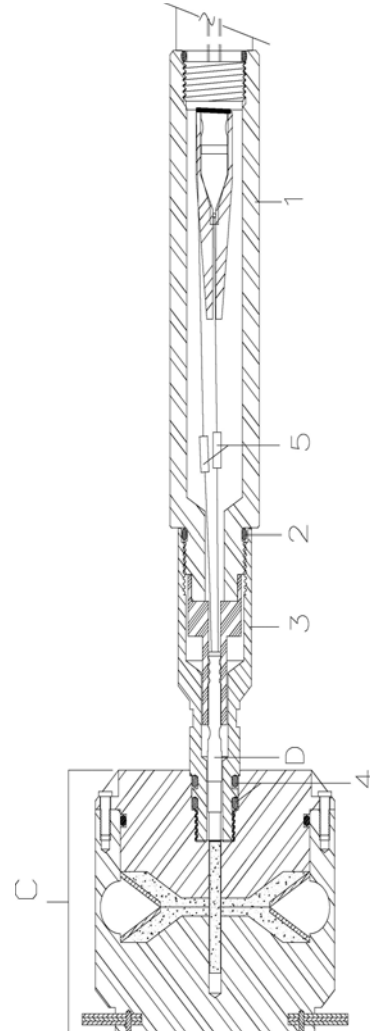

Outer Dia. [in (mm)]	Temp [F (C)]	Pressure [psi (MPa)]	Explosive Weight [lb (kg) (g)]	Recommended Application	Part Number
3.437 (87.3)	400 (204)	12,000 (82.7)	.183 (.083) (83)	4 1/2", 20#	CUT-3437-062NT
3.625 (92.1)	400 (204)	12,000 (82.7)	.183 (.083) (83)	4 1/2", 13.5#	CUT-3625-062NT
3.812 (96.8)	400 (204)	12,000 (82.7)	.183 (.083) (83)	5", 21#	CUT-3812-062NT
4.50 (114.3)	400 (204)	12,000 (82.7)	.309 (.140) (140)	5 1/2", 23#	CUT-4500-062NT
4.75 (120.7)	400 (204)	12,000 (82.7)	.309 (.140) (140)	5 1/2", 15.5#	CUT-4750-062NT
5.50 (139.7)	400 (204)	12,000 (82.7)	.617 (.280) (280)	6 5/8", 24#	CUT-5500-062NT
5.75 (146.1)	400 (204)	12,000 (82.7)	.617 (.280) (280)	7", 38#	CUT-5750-062NT

1.0 Assembly of NT Segmented Casing Cutters 3.437-in, 3.625-in and 3.812-in

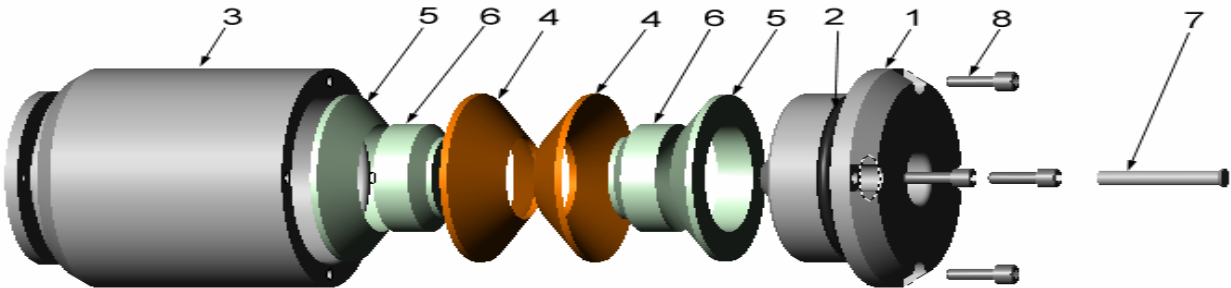

Figure 1: Exploded View, sizes 3.43-in - 3.812-in

1.1 Remove the O-ring (item #2) from its package and visually inspect it for cuts and cracks. Lightly lubricate it with grease and install it onto the Cap (item #1).

1.2 Unpack the cutter Pellets and Cartridge (item #5, #6, and #7).

1.3 Slide the inner cutter Pellet (item #6) into the outer cutter Pellet (item #5). See Figure 2.

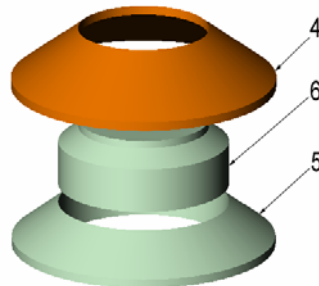

Figure 2: Liner/Pellet Assembly - Exploded View

1.4 Place the Liner (item #4) over the cutter Cartridges. See Figure 2.

1.5 Install the other Liner/Pellet assembly in the cutter Body (item #3) with the smaller diameter downward. The Liners should be facing each other.

1.6 Install the Cap (item #1) onto the Body. Secure in place with Cap Screws (item #8).

NT Segmented Casing Cutters for 4.500-in - 7.625-in Casing



1.7 Insert the Booster Cartridge (item #7) through the hole in the explosive assembly until the flared end seats in the Cap. See Figure 1.

2.0 Assembly of NT Segmented Casing Cutters 4.500 in, 4.750-in, 5.500-in, 5.750-in and 6.375-in

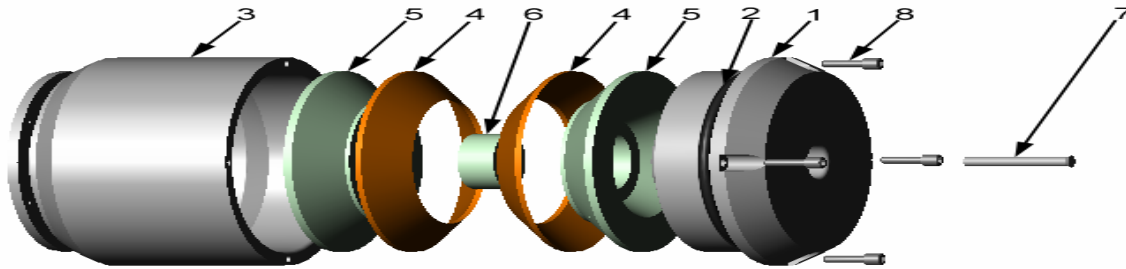

Figure 3: CUT-5500-062NT - Exploded View

2.1 Remove the O-ring (item #2) from its package and visually inspect it for cuts or cracks. Lightly lubricate O-ring with grease and install the O-ring onto the Cap (item #1).

2.2 Place the Body (Item #3) onto a flat surface with the open end upward for assembly.

2.3 Unpack the Pellets (item #5 and #6) and the Cartridge (item #7).

2.4 Insert a cutter Pellet (item #5) with the larger flat surface, positioned down into the recess in the bottom of the Body, see Figure 4. The contour of the Pellet should fit the contour of the Body's interior surface.

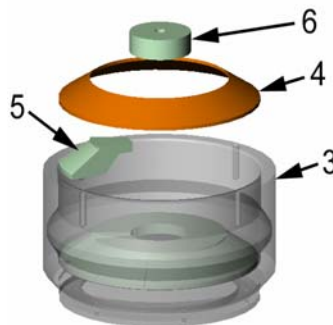

Figure 4: Pellet/Liner Assembly - Exploded View



NT Segmented Casing Cutters for 4.500-in - 7.625-in Casing

- 2.5** Repeat installation of Pellets with each Pellet touching another until the Pellets make a complete circle, see Figure 4.
- 2.6** Install a Liner (item #4) over the Pellets with the larger diameter downward to fit the contour of the Pellets. The Liner should fit tightly onto the Pellets.
- 2.7** Insert the center Pellet (item #6) into the hole left by the Pellets.
- 2.8** Install another Liner with the larger diameter upward on top of the first Liner.
- 2.9** Insert a cutter Pellet (item #5) with the smaller flat surface positioned down into the area between the Liner and the center Pellet. The contour of the Pellet should fit the contour of the Liner.
- 2.10** Repeat installation of Pellets with each Pellet touching another until the Pellets make a complete circle. The last Pellets should allow all the Pellets to fit tightly inside the Liner.
- 2.11** Install the Cap (item #1) onto the Body. Secure in place with Cap Screws (item #8).
- 2.12** Insert the Booster Cartridge (item #7) through the hole in the explosive assembly until the flared end seats in the Cap, see Figure 3.

3.0 Arming NT Casing Cutters

 **Warning: Always follow API RP-67 guidelines when arming electrical detonators!**

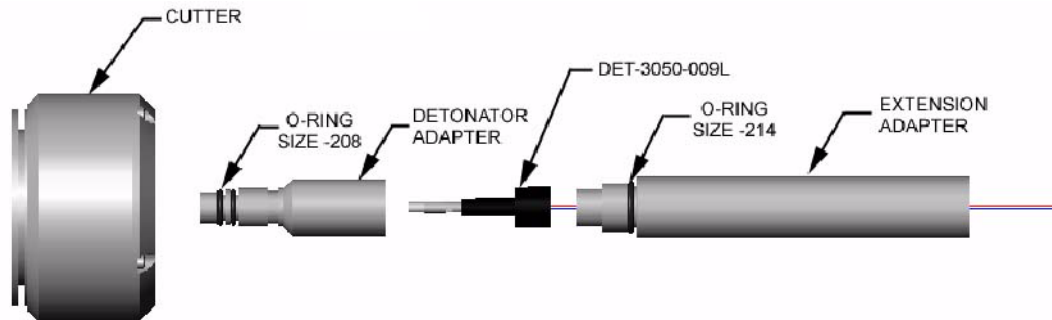

Figure 5: Arming Method for NT Casing Cutters - Exploded View

- 3.1** Remove the detonator from its package.
- 3.2** Insert the detonator into a safety shield.
- 3.3** Measure the resistance of the detonator between the two lead wires with a blaster's multimeter. The detonator should read 51 Ohms \pm 5 Ohms.
- 3.4** Remove the O-rings from their package and visually inspect them for cuts or cracks. Lightly lubricate O-rings with grease.
- 3.5** Install the 214 O-ring onto the Extension Adapter, and the 208 O-rings onto the detonator adapter.
- 3.6** Insert the detonator leadwires through the hole in the Extension Adapter.
- 3.7** Electrically connect the detonator leadwires to the wireline or toolstring.
- 3.8** Mechanically connect the Extension Adapter to the wireline toolstring.
- 3.9** Insure the wireline is shunted through the shooting panel.



NT Segmented Casing Cutters for 4.500-in - 7.625-in Casing

3.10 Remove the detonator from the safety shield and install the booted portion of the detonator over the end of the Extension Adapter.

3.11 Insert the detonator into the detonator Adapter and thread it onto the Extension Adapter and toolstring.

3.12 Thread the Cutter onto the detonator Adapter.

3.13 The tool is armed and ready to run in hole.

NT Segmented Casing Cutters for 4.500-in - 7.625-in Casing

