



# Drill Collar Severing Tools Dual Fire - EBW Initiated

MAN-REC-SEV (R06)

## Owen Oil Tools

12001 CR 1000

Godley, Texas, 76044, USA

Phone: +1 (817) 551-0540

Fax: +1 (817) 551-1674

[www.corelab.com/owen](http://www.corelab.com/owen)

**Warning:** Use of Owen equipment contrary to manufacturer's specifications or operating instructions may result in property damage, serious injury or fatality. If you are not trained in the handling and use of explosive devices, do not attempt to use or assemble any Owen perforating systems or Owen firing devices.

This technology is regulated by and, if exported, was exported from the United States in accordance with the Export Administration Regulations (EAR). Diversion contrary to U.S. law is prohibited. Export and/or re-export of this technology may require issuance of a license by the Bureau of Industry and Security (BIS), U.S. Department of Commerce. Consult the BIS, the EAR, and/or Owen Compliance Services, Inc. to determine licensing requirements for export or re-export of this technology.

This document contains Confidential Information of Owen Oil Tools LP (Owen) and is furnished to the customer for information purposes only. This document must not be reproduced in any way whatsoever, in part or in whole, or distributed outside the customer organization, without first obtaining the express written authorization of Owen. This document is the property of Owen and returnable upon request of Owen.

© 2008 Owen Oil Tools

---

# Drill Collar Severing Tools Dual Fire - EBW Initiated

---





## Overview

## Description

Drill Collar Severing Tools are designed to sever drill collars and heavyweight drill pipe reliably and safely during Pipe Recovery Operations.

## Operation

Drill Collar Severing Tools provide a quick and effective solutions to sever heavyweight drill pipe and drill collars. These severing tools utilize Exploding Bridgewire technology to increase safety during pipe recovery operations and increase the performance of the tools.

Drill Collar Severing Tools should be used when drill pipe becomes stuck in the well or during plug and abandonment (P & A) operations. The tool with the largest possible diameter capable of running in the stuck pipe should be chosen to achieve maximum performance. Owen's severing tools are to be shot in the tool joint above the stuck point. It is also recommended that tension be applied to the tubing prior to detonation of the Tubing Cutter to assist in the removal of stuck tubulars.

Drill Collar Severing Tools utilize EBWs to simultaneously detonate an explosive column from both ends. The convergence of the detonated explosive columns creates a shock wave collision, severing the tubular. The EBWs increased precision in function time over standard Mach-wave severing tools maximizes performance and collision of the explosive column. Incorporation of the EBW into the dual fire severing tool adds increased safety against rig-site hazards such as R-F transmitters, cathodic protection, and stray voltages. All safety rules and regulations should be strictly followed when storing, handling, assembling, and using these severing tools and/or detonators. Safety precautions should be taken in accordance with your company's safety policies, governmental regulations, and the American Petroleum Institute Recommended Practice 67 (API RP-67).

Drill Collar Severing Tools come standard with HMX explosive powder rated to 400° F (204° C) for 1 hour. Cutters are also available with HNS [500° F (260° C) - 1 hour] by special order.

# Drill Collar Severing Tools Dual Fire - EBW Initiated



## Specifications and Schematics

| Item | Description         | 1 3/8 in. Tool | 1 3/4 in. Tool | 2 in. Tool     | 2 3/8 in. Tool |
|------|---------------------|----------------|----------------|----------------|----------------|
| 1    | Hardware Kit        | SEV-1375-200   | SEV-1750-200   | SEV-2000-200   | SEV-2375-200   |
| 2    | Splice Boot         | PUR-0210-001   | PUR-0210-001   | PUR-0210-001   | PUR-0210-001   |
| D    | Detonator           | EBW-PSCI-401   | EBW-PSCI-401   | EBW-PSCI-401   | EBW-PSCI-401   |
|      | Required Detonators | 2              | 2              | 2              | 2              |
| P    | Pellet              | CRT-3030-400FV | CRT-3030-400GV | CRT-3030-400JV | CRT-3030-400LV |
|      | Required Pellets    | 28             | 44             | 60             | 88             |

- Please note that item #2, the detonators, and the pellets must be ordered separately.
- HNS Pellets available by special order. Parts should be ordered by replacing the 400 with 500, for example CRT-3030-500X.

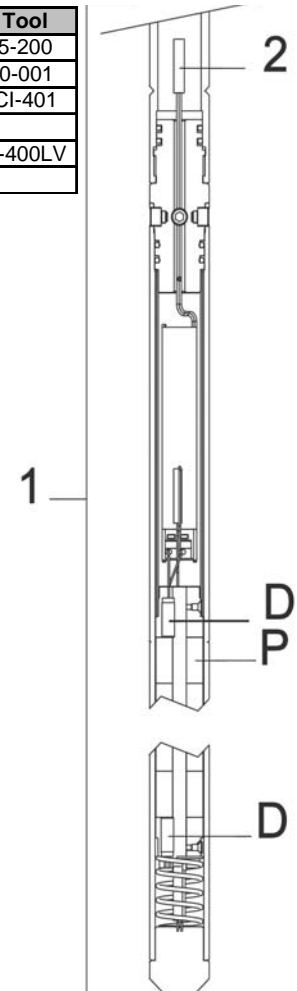

| Outer Dia. [in (mm)] | Temp [F (C)] | Pressure [psi (MPa)] | Explosive Weight [lb (kg) (g)] | Recommended Application                      | Hardware Part Number | Detonator Part Number (2 Required) | Pellet Part Number | Required Pellets |
|----------------------|--------------|----------------------|--------------------------------|--|----------------------|------------------------------------|--------------------|------------------|
| 1.375 (34.9)         | 400 (204)    | 20,000 (137.9)       | 1.4 (.64) (640)                | 2 7/8"-3 1/2" Drill Collar (up to 4 1/4" OD) | SEV-1375-200         | EBW-PSCI-401                       | CRT-3030-400FV     | 28               |
| 1.750 (44.5)         | 400 (204)    | 20,000 (137.9)       | 2.4 (1.1) (1,100)              | 3 1/2"-5" Drill Collar (up to 6 1/4" OD)     | SEV-1750-200         | EBW-PSCI-401                       | CRT-3030-400GV     | 44               |
| 2.000 (50.8)         | 400 (204)    | 20,000 (137.9)       | 3.2 (1.48) (1,485)             | 4"- 6" Drill Collar (up to 8" OD)            | SEV-2000-200         | EBW-PSCI-401                       | CRT-3030-400JV     | 60               |
| 2.375 (60.3)         | 400 (204)    | 20,000 (137.9)       | 4.9 (2.2) (2,200)              | 7" 11" Drill Collar (up to 13" OD)           | SEV-2625-200         | EBW-PSCI-401                       | CRT-3030-400LV     | 88               |

## 1.0 Pre-Assembly and Pre-Check of Tools

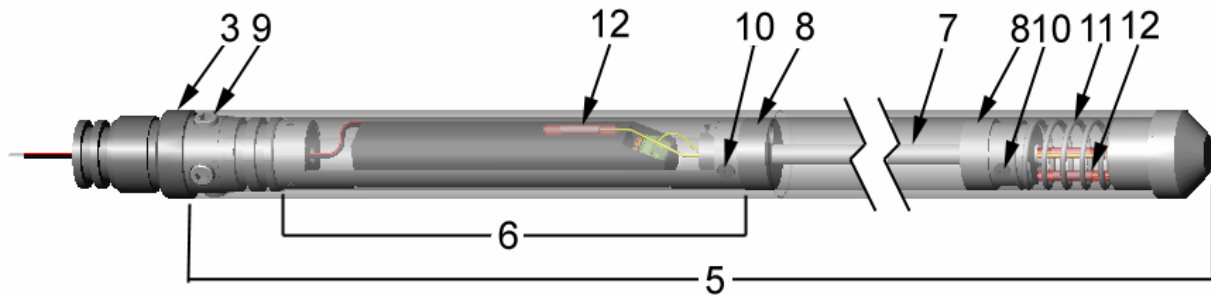

**Figure 1:** Drill Collar Severing Tool Shipping Assembly

**1.1** Remove all non-explosive items from the shipping container; this includes the shipping assembly shown in Figure 1, O-rings, and Cap Screws.

**1.2** Remove the Top Sub (item #3) with attached PX-1 Fireset assembly (item #6), center Tube assembly (item #7), End Alignment Washer (item #8), and Spring (item #11) from the Housing (item #5).

**1.3** Remove the End Alignment Washer and Spring from the center Tube assembly.

**1.4** Remove the O-rings from their package and visually inspect them for cuts or cracks. Lightly lubricate them with grease and install them on the Top Sub.

**1.5** Run the wires for the PX-1 Fireset through the hole at the top of the Pellet/detonator carriage assembly and through the Top Sub.

**1.6** Reference the PX-1 operating instructions included in the shipping assembly for further information regarding the PX-1 Fireset.

**1.7** The PX-1 input wires and the output sockets of the PX-1 Fireset should not be electrically connected to another component.

**1.8** Check for voltage across the output sockets of the PX-1 using a digital blaster's meter set on DC+ Voltage Scale, see Figure 2. Meter should read 0 Volts.

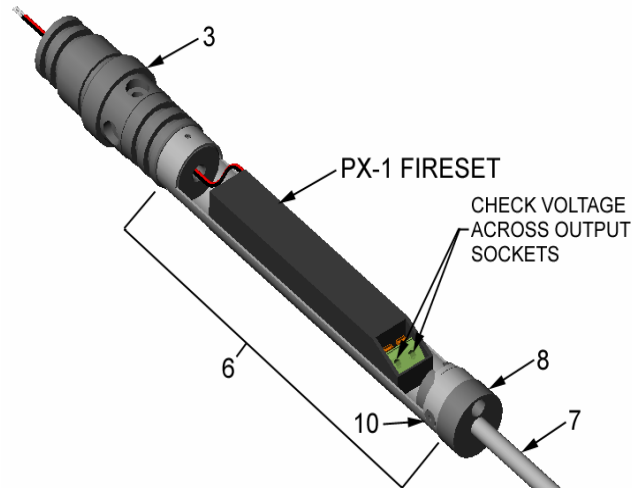

**Figure 2:** Checking Output Sockets of PX-1 for Voltage Prior to Arming

## 2.0 Arming the Tool



**Warning:** Always follow API RP - 67 guidelines when arming electrical detonators!



**Note:** Reference the PX-1 operating instructions included in shipping assembly for further information regarding the PX-1 fireset.!

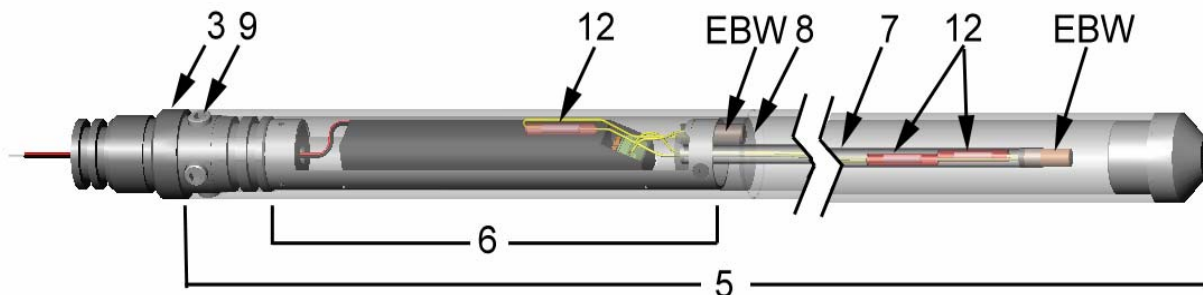
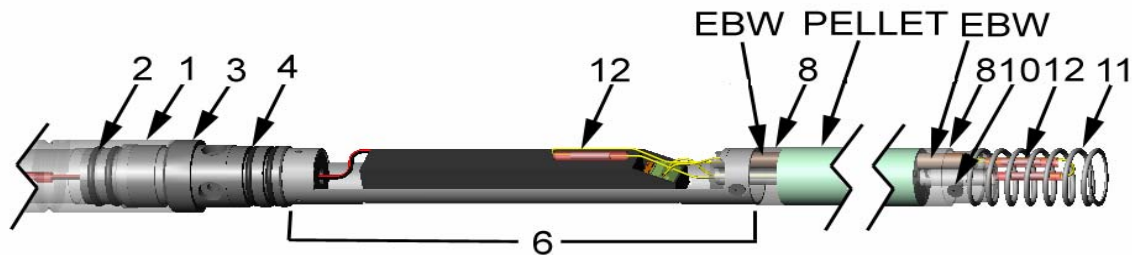

**Figure 3:** Arming a Drill Collar Severing Tool



- 2.1** Trim the exposed conductor of the wire from the center Tube assembly without the crimp sleeve, to 0.5 in (1.3 cm) of exposed wire. Insert the wire into one of the sockets of the PX-1.
- 2.2** Remove the EBW detonators from their packaging. Trim each wire to 0.5 in (1.3 cm) of exposed wire.
- 2.3** Insert one EBW, wire end first, into the Top Alignment Washer (item #12) near the PX-1.
- 2.4** Electrically connect the EBW to the top end of the tool, see Figure 3. One wire should be inserted into the empty socket of the PX-1 Fireset, and the other wire should be inserted into the Crimp Sleeve (item #12). Fold the exposed leadwire over itself, and crimp it in the Crimp Sleeve.
- 2.5** Electrically connect the other EBW to the bottom end of the center Tube assembly, see Figure 3. Fold each wire over itself and insert it into the Crimp Sleeve at the end of the tube and crimp in place.
- 2.6** Lightly tug each electrical connection to check the integrity of the electrical and mechanical connections.
- 2.7** Feed the Crimp Sleeves on the bottom end of the center Tube into the internal diameter of the Tube. The EBW should partially fit inside the end of the center Tube.
- 2.8** Insert the Top Sub with PX-1, EBWs, and related hardware into the Housing. Do not install Bottom Alignment Washer or Spring at this point. Secure in place with a minimum of two Cap Screws (item #9). The housing will act as a safety shield for connecting to the toolstring.
- 2.9** Electrically connect the wires to the toolstring. The red wire is the positive lead, and black/white wire is ground when shooting DC+. Switch the leads when shooting DC-.
- 2.10** Mechanically connect the Top Sub to the Extension Mandrel and toolstring.

### 3.0 Installation of Pellets



**Figure 4:** Pellets and Detonators Installed for Severing Tool

**3.1** Remove the housing from the Top Sub and attached assembly.

**3.2** Inspect the PX-1 Fireset assembly to insure the tab is down to hold the EBW in place.

**3.3** Remove the Pellets from the boxes and packaging:

- 1.375 in tools require 28 Pellets
- 1.750 in tools require 44 Pellets
- 2.000 in tools require 60 Pellets
- 2.375 in tools require 88 Pellets.

**3.4** Install a Pellet onto the center Tube assembly (item #7) over the EBW detonator. Slide the Pellet along the Tube until it shoulders up against the Carriage, see Figure 5. The top EBW should be in contact with the explosive Pellet.

**3.5** Repeat Step 3.2, shouldering each Pellet against one another.

**3.6** After all the Pellets are placed on the Carriage assembly, install the End Alignment Washer (item #8) on the Tube. Remove the detonator from the end of the center Tube before securing the Alignment Washer in place by tightening the Screw (item #10).

**3.7** Insert the EBW, output end first, into the Bottom Alignment Washer as shown in Figure 4. The EBW should be in contact with the explosive Pellet.

**3.8** Install the Spring over the end of the Alignment Washer. The Spring will hold the detonator in place.

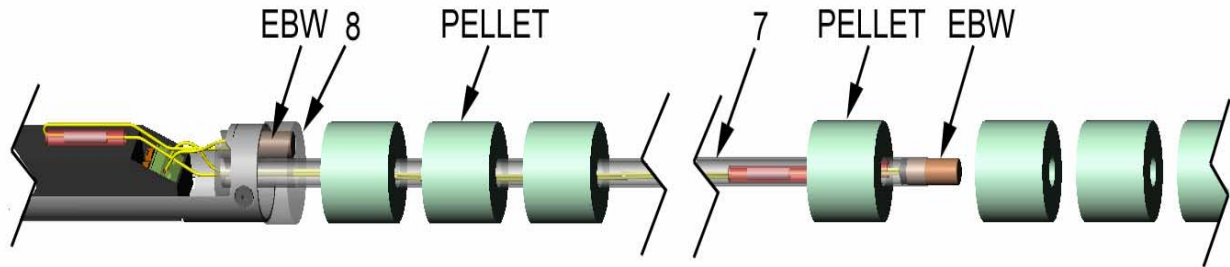

**Figure 5:** Installation of Pellets onto Center Tube Assembly.

## 4.0 Final Tool Assembly

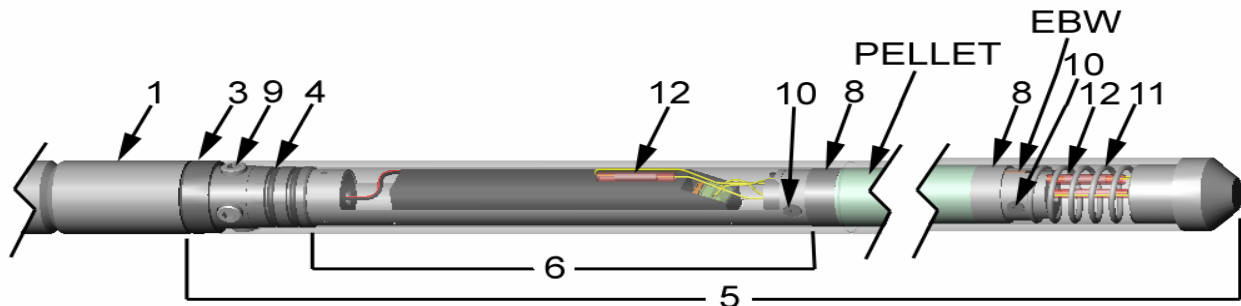

**Figure 6:** Fully Assembled Dual Fire Severing Tool

**4.1** Check all electrical connections of the EBWs to ensure electrical continuity between the PX-1 Fireset and the EBWs.

**4.2** Check all electrical wiring to prevent damage to wires when installing the Housing over the assembled tool.

**4.3** Slide the Housing (item #2) over the assembled tool.

**4.4** Secure the Housing to the Top Sub with Cap Screws (item #9).

**4.5** The tool is armed and ready to run in hole.

