



# 5.000 inch Vertical Shock Absorber

TC-300-5000-288

TC-300-5000-350

TC-300-5000-400

MAN-TC-300-5000 (R02)

## Owen Oil Tools

12001 CR 1000

Godley, Texas, 76044, USA

Phone: +1 (817) 551-0540

Fax: +1 (817) 551-1674

[www.corelab.com/owen](http://www.corelab.com/owen)

**Warning:** Use of Owen equipment contrary to manufacturer's specifications or operating instructions may result in property damage, serious injury or fatality. If you are not trained in the handling and use of explosive devices, do not attempt to use or assemble any Owen perforating systems or Owen firing devices.

Owen Oil Tools pre-assembles its tools as per the field operating manual. It is the responsibility of the purchaser to insure that this tool is assembled as required, prior to use.

This technology is regulated by and, if exported, was exported from the United States in accordance with the Export Administration Regulations (EAR). Diversion contrary to U.S. law is prohibited. Export and/or re-export of this technology may require issuance of a license by the Bureau of Industry and Security (BIS), U.S. Department of Commerce. Consult the BIS, the EAR, and/or Owen Compliance Services, Inc. to determine licensing requirements for export or re-export of this technology.

This document contains Confidential Information of Owen Oil Tools LP (Owen) and is furnished to the customer for information purposes only. This document must not be reproduced in any way whatsoever, in part or in whole, or distributed outside the customer organization, without first obtaining the express written authorization of Owen. This document is the property of Owen and returnable upon request of Owen.

© 2008 Owen Oil Tools

---

# 5.000 in. Vertical Shock Absorber

---



## 5.000 in. Vertical Shock Absorber

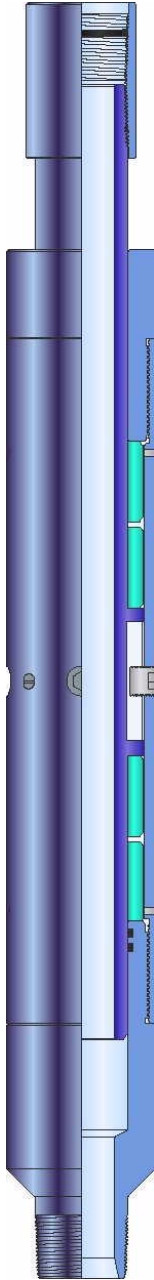

### Description

The 5.000 in. Vertical Shock Absorber is designed to run between the Packer and TCP guns. The purpose of the VSA is to protect delicate electronic gauges and mechanical tools from the severe shocks associated with the detonation of the TCP guns.

### Features and Benefits

- Protects Electronic Pressure Gauge
- Protects Mechanical Pressure Gauge
- Tool is rigid until guns fire
- Auto-rotational and sealed design

### Specifications

Thread Conn.	TC-300-5000-288: 2-7/8" EUE	
O.D.	5"	127 mm
I.D.	2.25"	57.15 mm
Make-up Length	41.00"	1041.4 mm
Max. Hydrostatic	20,000 psi	137.9 MPa
Max. Differential	15,000 psi	103.4 MPa
Tensile	250,000 lbs	111 205 daN

Thread Conn.	TC-300-5000-350: 3-1/2" EUE	
O.D.	5"	127 mm
I.D.	2.25"	57.15 mm
Make-up Length	47.25"	1200.15 mm
Max. Hydrostatic	20,000 psi	137.9 MPa
Max. Differential	15,000 psi	103.4 MPa
Tensile	250,000 lbs	111 205 daN

Thread Conn.	TC-300-5000-400: 3-1/2" I.F.	
O.D.	5"	127 mm
I.D.	2.25"	57.15 mm
Make-up Length	50.25"	1276.35 mm
Max. Hydrostatic	20,000 psi	137.9 MPa
Max. Differential	15,000 psi	103.4 MPa
Tensile	250,000 lbs	111 205 daN

# 5.000 in. Vertical Shock Absorber

---



## TC-300-5000-288BOM and Schematic

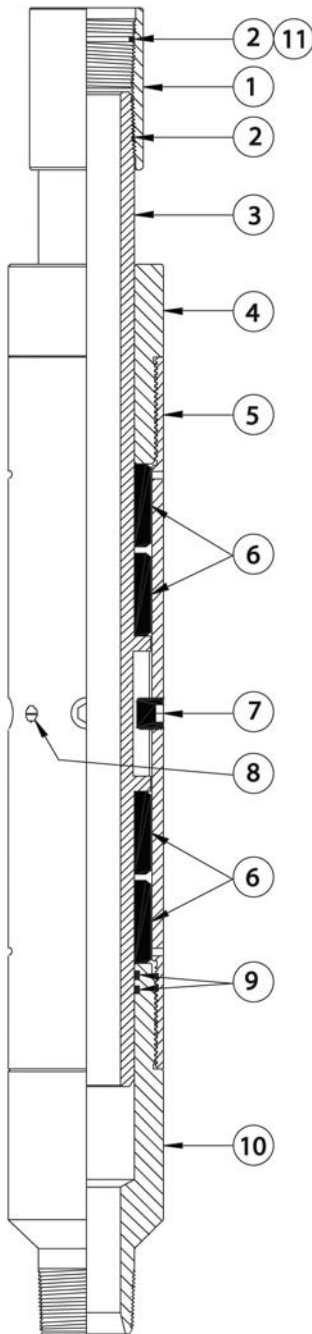

Item	Part No.	Qty	Description
--	TC-300-5000-288	--	5" Vertical Shock Absorber Assembly with 2-7/8 EUE connections.
1	CC-001-2875-100	1	Top Sub, 2-7/8 EUE X 2-7/8 EUE
2*	MI-305-2875-000	2	API Seal, 2-7/8 EUE
3	TC-300-0008-000	1	Mandrel
4	TC-300-0009-000	1	Retainer
5	TC-300-0010-000	1	Housing
6*	TC-300-0011-000	4	Rubber Elements
7*	PF-002-100F-088	4	Lock Screws
8*	SET-3500-022	4	Shear Screws
9*	OOO-N569-338	2	O-Ring N-90
10	TC-300-0012-000	1	Bottom Sub 2-7/8 EUE
--	TC-300-5000-099	--	Re-dress Kit, 2-7/8 EUE VSA
--	MAN-TC-300-5000	--	Assembly Manual
<b>Item Part No. Qty Description</b>			
--	TC-300-5000-099	--	Re-dress Kit, 2-7/8 EUE VSA
*	Indicates items in the Re-dress Kit, same quantities		

## TC-300-5000-350 BOM and Schematic

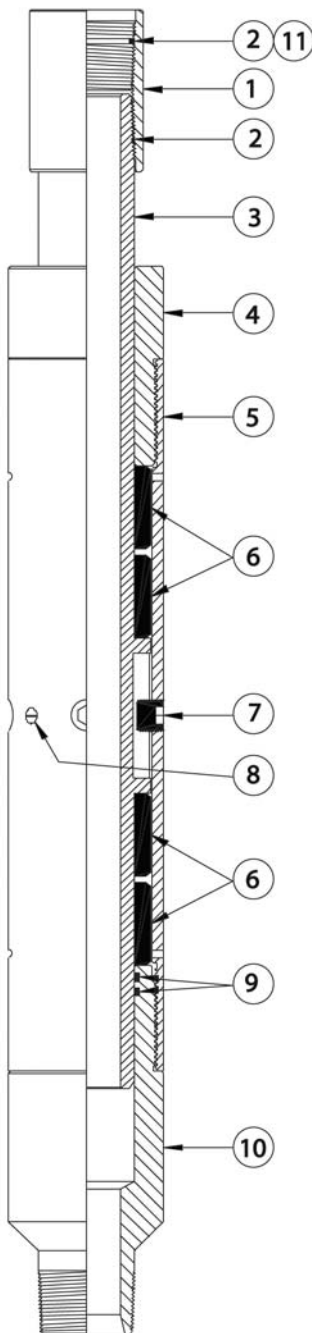

Item	Part No.	Qty	Description
--	<b>TC-300-5000-350</b>	--	<b>5" Vertical Shock Absorber Assembly with 3-1/2 EUE connections.</b>
1	TC-300-0015-000	1	Top Sub, 3-1/2 EUE X 2-7/8 EUE
2*	MI-305-2875-000	1	API Seal, 2-7/8 EUE
3	TC-300-0008-000	1	Mandrel
4	TC-300-0009-000	1	Retainer
5	TC-300-0010-000	1	Housing
6*	TC-300-0011-000	4	Rubber Elements
7*	PF-002-100F-088	4	Lock Screws
8*	SET-3500-022	4	Shear Screws
9*	OOO-N569-338	2	O-Ring N-90
10	TC-300-0016-000	1	Bottom Sub, 3-1/2 EUE
11*	MI-305-3500-000	1	API seal, 3-1/2 EUE
--	TC-300-5000-399	--	Redress kit, 3-1/2 EUE VSA
--	MAN-TC-3000-5000	--	Assembly Manual
Item	Part No.	Qty	Description
--	<b>TC-300-5000-399</b>	--	<b>Redress kit, 3-1/2 EUE VSA</b>
*	Indicates items in the Redress Kit, same quantities		

## TC-300-5000-400 BOM and Schematic

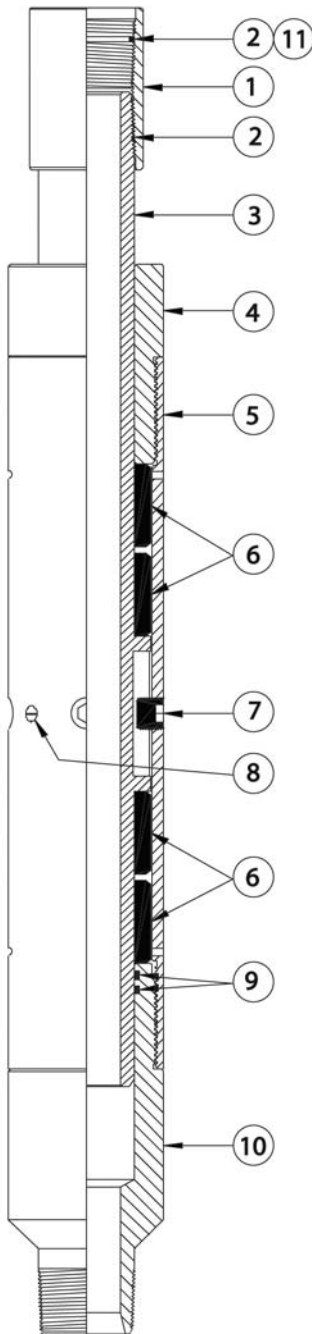

Item	Part No.	Qty	Description
--	<b>TC-300-5000-400</b>	--	<b>5" Vertical Shock Absorber Assembly. with 3-1/2 IF connections.</b>
1	TC-300-0013-000	1	Top Sub, 3-1/2 IF X 2-7/8 EUE
2*	MI-305-2875-000	1	API Seal, 2-7/8 EUE
3	TC-300-0008-000	1	Mandrel
4	TC-300-0009-000	1	Retainer
5	TC-300-0010-000	1	Housing
6*	TC-300-0011-000	4	Rubber Elements
7*	PF-002-100F-088	4	Lock Screws
8*	SET-3500-022	4	Shear Screws
9*	OOO-N569-338	2	O-Ring N-90
10	TC-300-0014-000	1	Bottom Sub, 3-1/2 IF
--	TC-300-5000-499	--	Redress kit, 3-1/2 IF VSA
--	MAN-TC-300-5000	--	Assembly Manual
<b>Item Part No. Qty Description</b>			
--	<b>TC-300-5000-499</b>	--	<b>Redress kit, 3-1/2 IF VSA</b>
*	Indicates items in the Redress Kit, same quantities		

## Exploded View

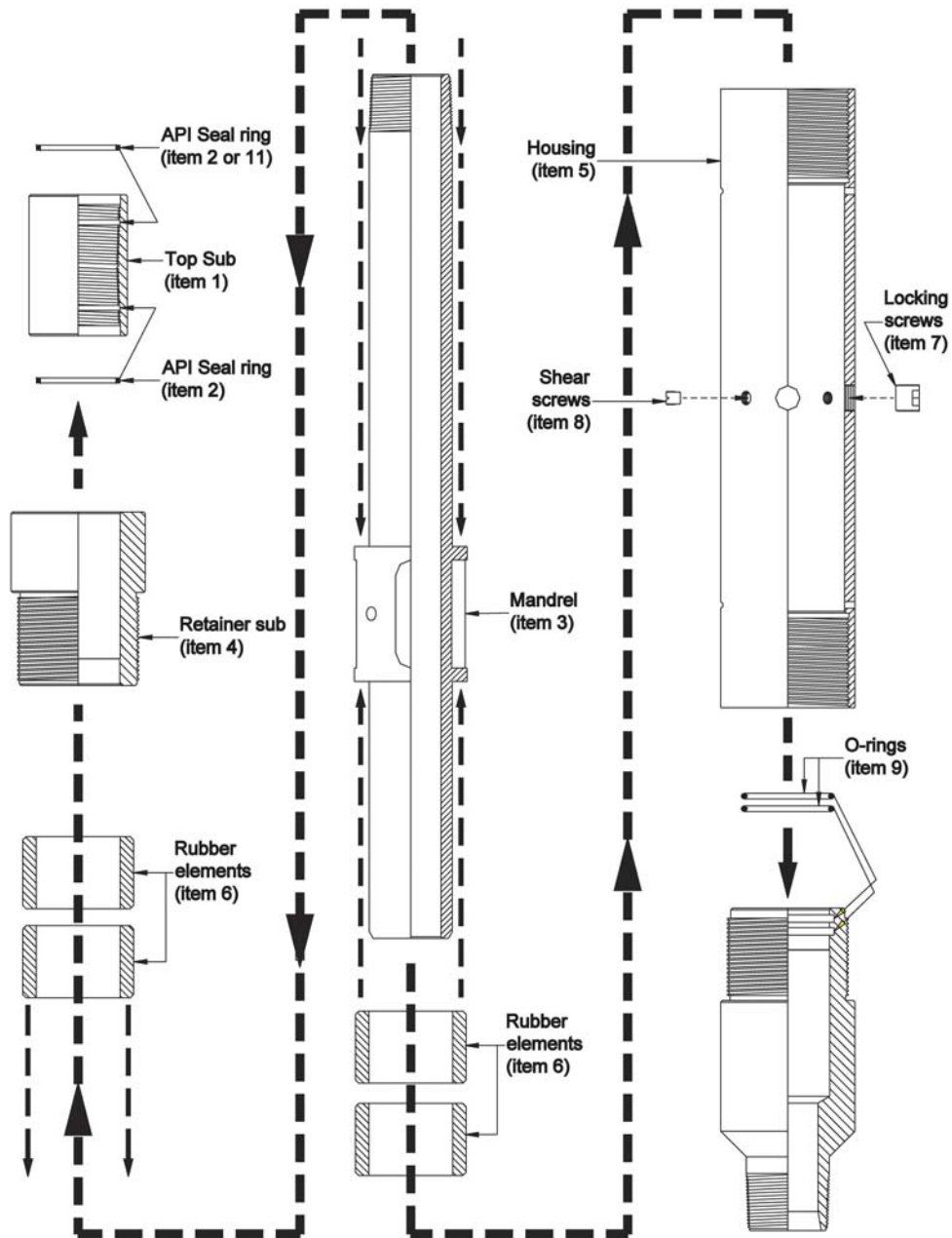

 *Note: Check all items against the parts list to be sure of having the correct parts and quantities.*

 *Note: Check for any damage to the parts which would prevent the part from being assembled correctly, easily and safely.*

## 1.0 Assembly

**1.1** Secure the Shock Absorber Housing (item #5) into a large holding device or Baker style type vise. The holding device must be able to support the total weight of the assembled tool. When securing housing, make sure to let the shear screw and locking screw holes to remain visible and unobstructed. Leave the tool in the holding device during the full assembly process.

**1.2** Install the two (2) internal O-rings (item #9) into the Bottom Sub's (item #10) O-ring grooves. Apply grease to the O-rings and internal O-ring surface. Apply a thin coat of grease to the exterior threads of the Bottom Sub and the internal threads of both ends of the housing. Because the housing is symmetrical, thread the Bottom Sub about half-way into one of the ends of the housing. It will be tightened up later in the assembly procedure.

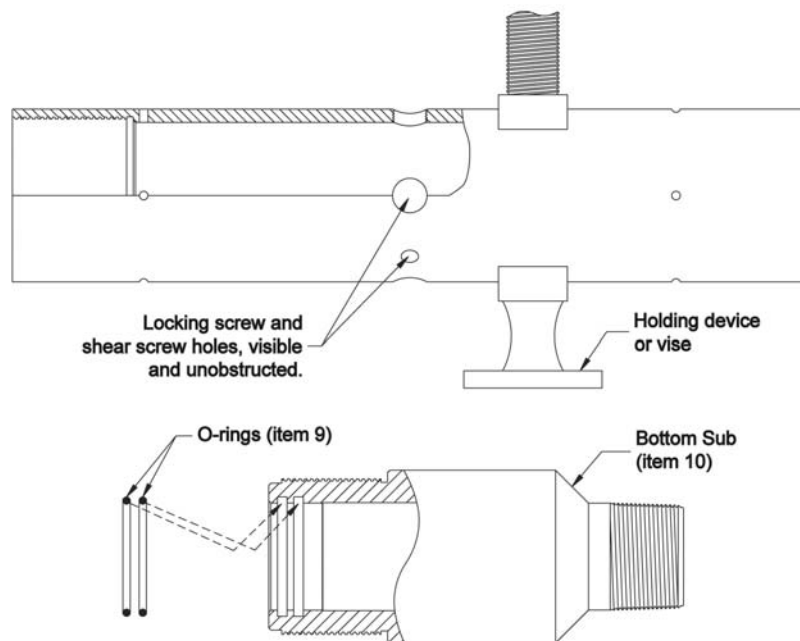

**1.3** Next, install two (2) of the Rubber Elements (item #6) onto the bottom end of the Mandrel (item #3). The bottom end **is not** threaded. Apply a thin coating of grease on the bottom section of the Mandrel and slide two (2) of the four (4) Rubber Elements onto the bottom end of the Mandrel.

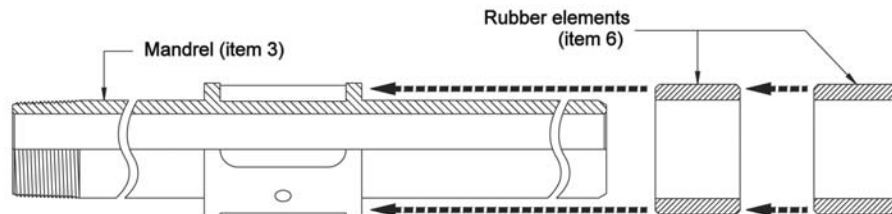

**1.4** After the elements are on the Mandrel, apply a thin layer of grease to the outer surfaces of the Rubber Elements and the upper section of the Mandrel, covering approximately 6 inches from the slotted area. Insert the Mandrel into the housing until the bottom end of the Mandrel comes in contact with the O-rings in the Bottom Sub.

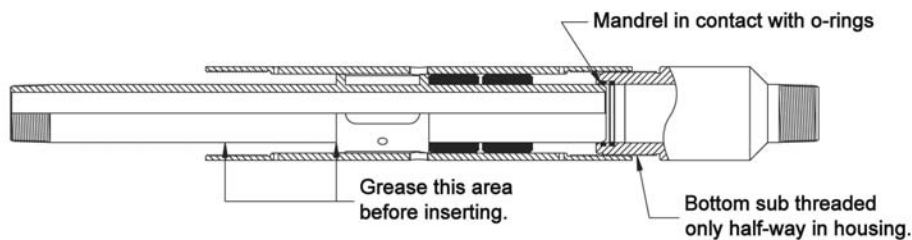

**1.5** Apply a thin layer of grease to the outer surface of the two (2) remaining Rubber Elements and slide them over the upper section of the Mandrel, and down inside the housing until they bottom out. With the elements fully inserted, there should be a few housing threads exposed to act as starting threads for the next step in the assembly procedure. If not, back the Bottom Sub out a few turns and push the Mandrel and elements in until they contact with the O-rings again.

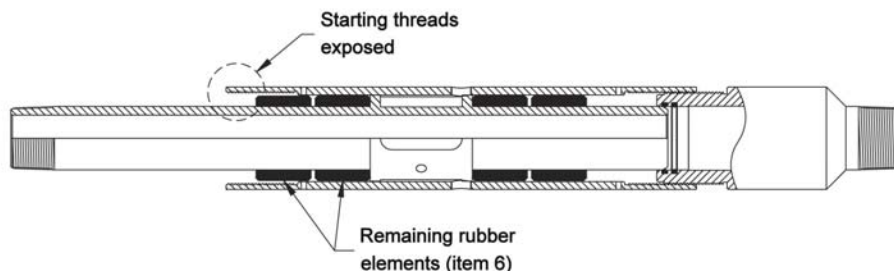

**1.6** Apply grease to the threads of the Shock Absorber Retainer (item #4), slide it over the Mandrel and thread it into the housing.

*Note: You must put a back-up wrench on the bottom sub at this time to prevent the bottom sub from turning and backing out of the housing.*

Thread the retainer sub all the way in and tighten. Now place the back-up wrench on the retainer sub, then thread the bottom sub into the housing and tighten. This step also pushes the Mandrel past the O-rings in the Bottom Sub and comes close to aligning the threads holes in the housing with the holes and slots in the Mandrel.

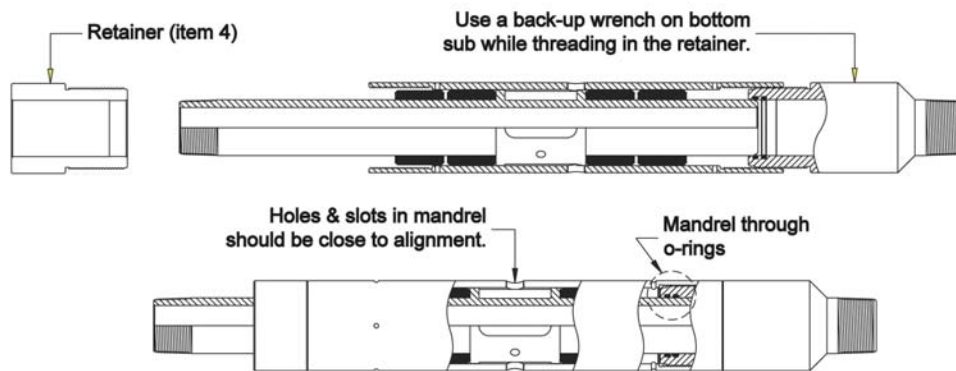

**1.7** With both the retainer and Bottom Sub tight, rotate the Mandrel until the slots and holes are aligned with the proper tapped holes in the housing (large tapped holes for the slots and the smaller tapped holes for the counterbore holes). The Mandrel might have to be moved in an up or down direction to get perfect alignment of the smaller holes. This is easily done while rotating the Mandrel. With the holes and slots in perfect alignment, thread in the four (4) Locking Screws (item #7) and the four (4) Shear Screws (item #8). The tops of the screws should be flush or just below the OD of the housing.

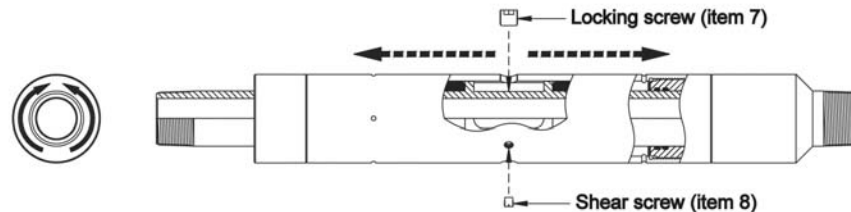

# 5.000 in. Vertical Shock Absorber



**1.8** Install the API Seal Ring (item #2) into the Mandrel side of the Top Sub (item #1) to be used. If using the 2-7/8 EUE Top Sub, install a second API Seal Ring in opposite end of the sub. If assembling for the 3-1/2 EUE connections, install a API Seal Ring (item #11) in the opposite end of the Top Sub. If assembling for the 3-1/2 IF connections, no additional Seal Rings are necessary. With the seal rings installed, apply grease to the threads of the Mandrel, thread on the Top Sub and tighten. The 5 in. Vertical Shock Absorber is now complete and can be removed from the holding device.

