



Mechanical Safety Impact Firing Head (LP)

TC-012-1687-000

MAN-TC-012-1687-000 (R01)

OWEN OIL TOOLS

12001 Cr 1000
Godley, Texas, 76044, USA
Phone: +1 (817) 551-0540
Fax: +1 (817) 551-1674
www.corelab.com/owen

Warning: use of owen equipment contrary to manufacturer's specifications or operating instructions may result in property damage, serious injury or fatality. If you are not trained in the handling and use of explosive devices, do not attempt to use or assemble any owen perforating systems or owen firing devices.

This technology is regulated by and, if exported, was exported from the united states in accordance with the export administration regulations (EAR). Diversion contrary to U.S. Law is prohibited. Export and/or re-export of this technology may require issuance of a license by the bureau of industry and security (BIS), U.S. Department of Commerce. Consult the BIS, the EAR, and/or Owen Compliance Services, Inc. To determine licensing requirements for export or re-export of this technology.

This document contains confidential information of Owen Oil Tools LP (Owen) and is furnished to the customer for information purposes only. This document must not be reproduced in any way whatsoever, in part or in whole, or distributed outside the customer organization, without first obtaining the express written authorization of owen. This document is the property of owen and returnable upon request of Owen.



Mechanical Safety Impact Firing Head (LP)

PRODUCT INFORMATION:

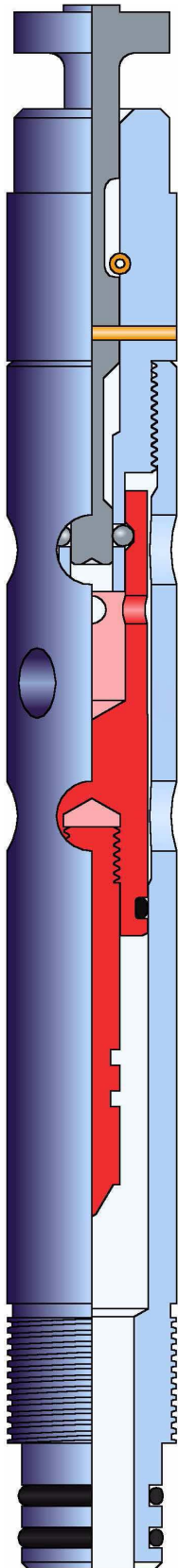

DESCRIPTION:

The Mechanical Safety Impact Firing Head is designed to be the primary firing system on all Wide Nose Drop Bar TCP operations. Designed to meet API RP-67 safety recommendations, the Mechanical Safety Impact Firing Heads require both the drop bar action as well as a minimum hydrostatic to fire. Two models are utilized to cover the pressure ranges normally anticipated in TCP operations. The Low Pressure (LP) version requires 300 psi (minimum hydrostatic pressure) to operate. When the Wide Nose Drop Bar strikes the firing head, the impact breaks the coiled pin, which secures the Release Rod and pushes it down. This movement releases the firing pin driving it into the percussion detonator and fires the gun(s). This Firing Head must be run in conjunction with an Impact Firing Head No-Go or a Tubular Collar No-Go to meet safety requirements. Refer to catalog page TC-170-0.3 for details.

ADVANTAGES:

- Electrical currents, natural or man-made cannot detonate the Safety Impact Firing Heads.
- Ideal for all Wide Nose Drop Bar Firing operations where a minimum of 300 psi hydrostatic exists.
- Ideal for heavy mud.
- Operates with a Wide Nose Drop Bar.

SPECIFICATIONS:

O.D.	1.69 IN	43 MM
MAKE-UP LENGTH	11.00 in	279 mm
MAX. TEMPERATURE ¹	250°F	121° C
MAX. HYDROSTATIC	8,000 psi	55.2 MPa
MIN. HYDROSTATIC	300 psi	2.1 MPa

¹The maximum temperature can be increased to 400°F (204°C) by substituting the 90 durometer Nitrile O-Rings with 90 durometer Viton O-Rngs. Refer to the Time vs Temperature chart for Explosives to confirm any explosives requirements.

Note: This tool should be used with Wide Nose Drop Bars.



Mechanical Safety Impact Firing Head (LP)

PRODUCT INFORMATION:

BILL OF MATERIALS:

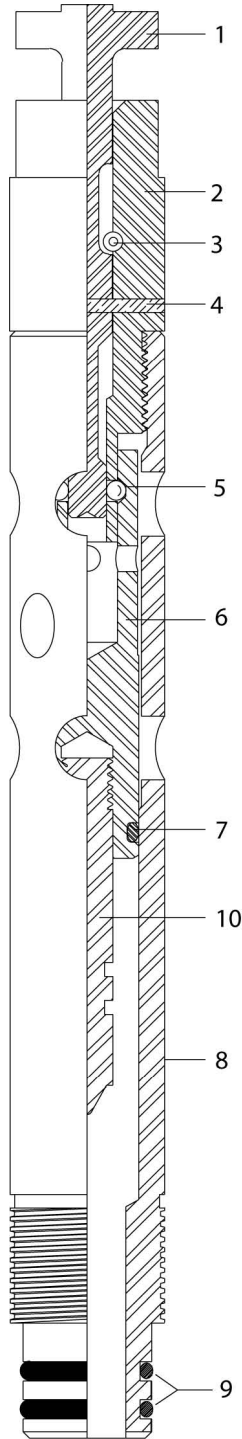

ITEM	PART NUMBER	QTY	DESCRIPTION
--	TC-012-1687-000	--	Mechanical Safety Impact FH (LP)
1	TC-012-0001-000	1	Release Rod, S.I.
2	TC-012-0002-000	1	Body, Release Rod, S.I.
3*	PF-130-0188-125	1	Roll Pin
4*	PF-120-0188-150H	1	Spirol [®] , Coiled Pin
5*	ST-040-0188-000	4	Retaining Balls
6	TC-012-0004-000	1	Ball Retainer Piston (L.P.), S.I.
7*	OOO-N569-210	1	O-Ring
8	TC-012-0007-000	1	Body, (L.P.) Heavy Duty S.I.
9*	OOO-N569-214	2	O-Ring
10*	TC-012-0005-000	1	Firing Pin, C.P. Detonator
--	TC-012-1687-000V	--	Mechanical Safety Impact FH (LP)(H.T.)
--	TC-012-1500-099P	--	Re-Dress Kit, Safety Impact Firing Head (L.P.)
--	TC-012-1500-399P	--	Re-Dress Kit, Safety Impact Firing Head (L.P.)(H.T.)
--	MAN-TC-012-1687-000	--	Assembly Manual

* Denotes items in the Redress Kits

High Temperature Firing Head and Redress Kit contain Viton 90 O-Rings.



Mechanical Safety Impact Firing Head (LP)

PRODUCT INFORMATION:

BILL OF MATERIALS: Hook-Up

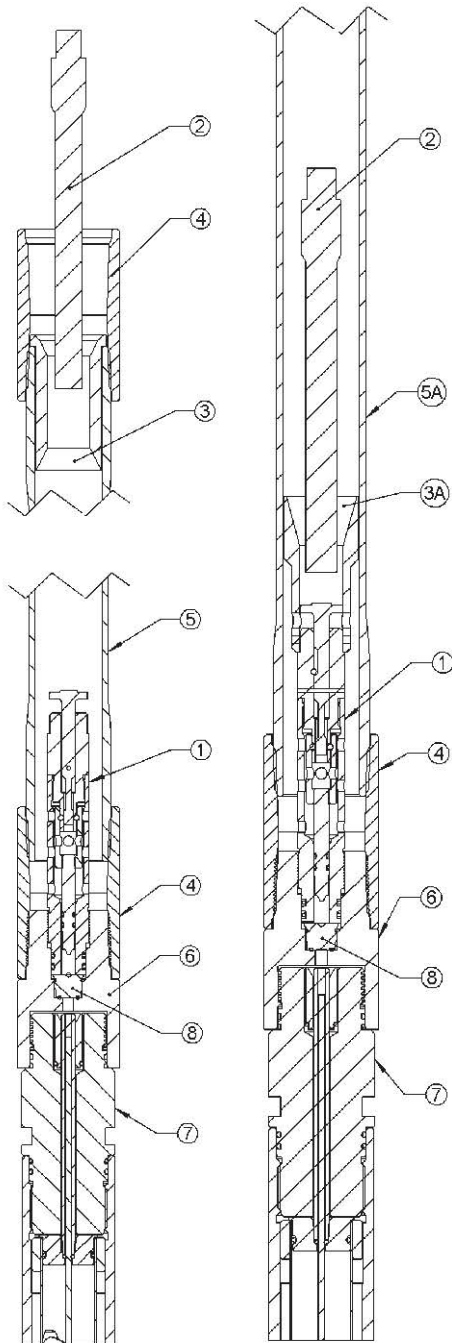

ITEM	PART NO.	DESCRIPTION
1	TC-012-1687-000	Safety Impact Assy. (H.D.)(L.P.)
	TC-012-1687-000V	Safety Impact Assy. (H.D.)(L.P.)(H.T.)
2	TC-136-1250-006	Drop Bar Assy. 6' (Sectional)
	TC-136-1250-010	Drop Bar Assy. 10' (Sectional)
	TC-138-1250-008	Drop Bar 8' (Solid)
	TC-138-1250-010	Drop Bar 10' (Solid)
3	TC-170-2375-000	Tubular No-Go for 2-3/8
	TC-170-2875-000	Tubular No-Go for 2-7/8
	TC-170-3500-000	Tubular No-Go for 3-1/2
3A	TC-010-0022-110	Impact No-Go for 2-3/8 (1.39" I.D.)
	TC-010-0029-110	Impact No-Go for 2-7/8 (1.39" I.D.)
	TC-010-0030-110	Impact No-Go for 3-1/2 (1.39" I.D.)
4	CC-001-2375-000	Collar for 2-3/8 EUE
	CC-001-2875-000	Collar for 2-7/8 EUE
	CC-001-3500-000	Collar for 3-1/2 EUE
5	CC-101-2347-002	Pup Joint 2-3/8 EUE (2' length)
	CC-101-2865-002	Pup Joint 2-7/8 EUE (2' length)
	CC-101-3593-002	Pup Joint 3-1/2 EUE (2' length)
5A	--	Tubing
6	TC-005-0001-000	Detonator Body with 2-3/8 EUE Pin, 3-1/8" O.D.
	TC-005-0003-000	Detonator Body with 2-7/8 EUE Pin, 3-11/16" O.D.
	TC-005-0004-000	Detonator Body with 3-1/2 EUE Pin, 4-1/2" O.D.
7	--	Owen Top Gun Sub
8	Reference	Percussion Detonator

Exploded View

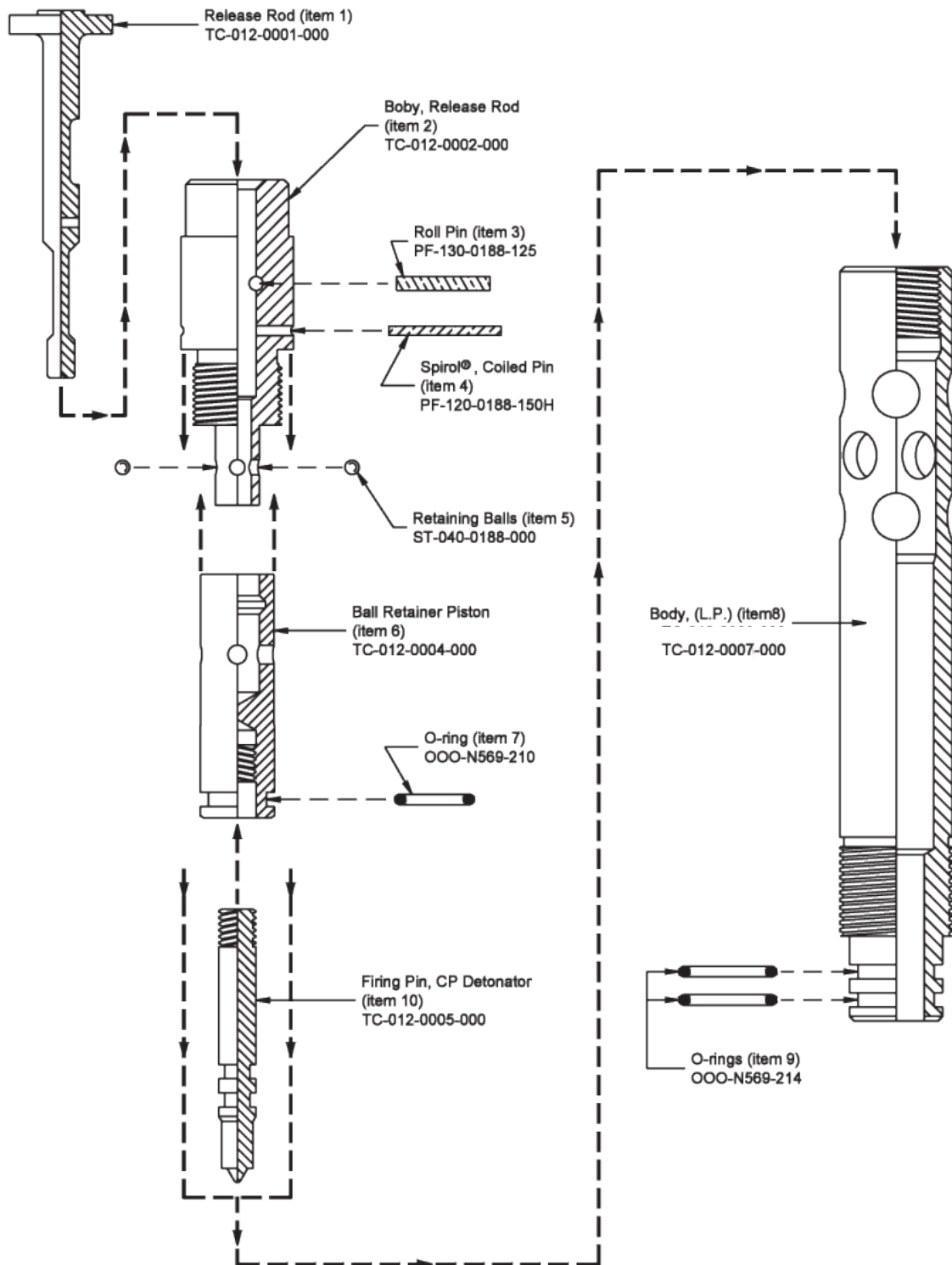



Warning: *The assembly of this tool requires the handling of an Explosive Device and all safety precautions must be and adhered to observed!*



Note: *Check all items against the parts list to be sure of having the correct parts and quantities.*



Note: *Check for any damage to the parts which would prevent the part from being assembled correctly, easily and safely.*

1.0 Assembly

- 1.1 Install the Release Rod (item #1) into the Release Rod Body (item #2) so that the milled flat on the Release Rod is in alignment with Roll Pin hole.

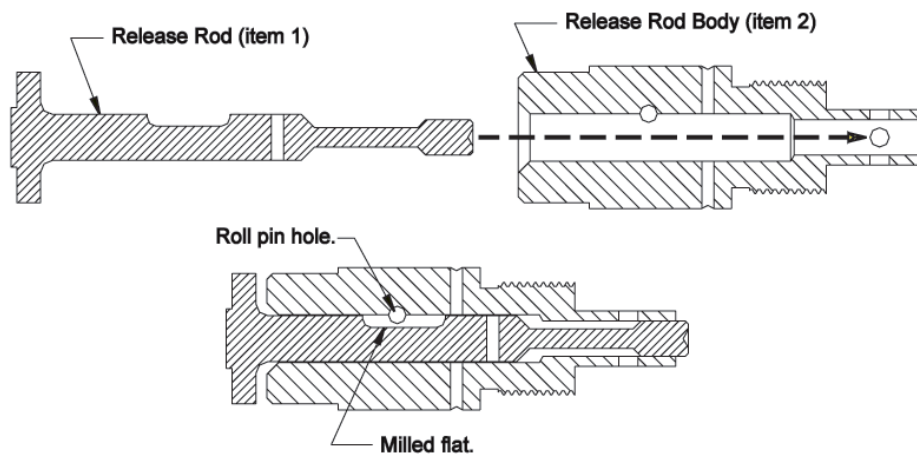

- 1.2 Insert and hammer in the Roll Pin (item #3) until the pin ends are flush with the rod body. Release Rod should slide easily without binding. Set aside.

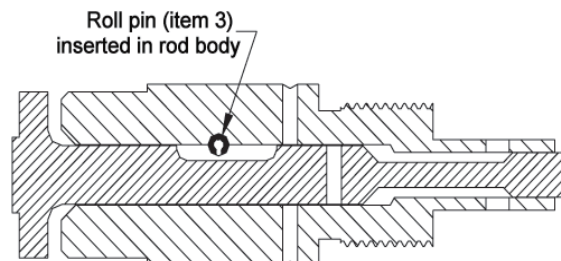

- 1.3 Apply a small amount of grease to the threads of the Firing Pin (item #10). Thread the Firing Pin into the Ball Retainer Piston (item #6) and tighten. Insert the assembled Ball Retainer Piston and Firing Pin into the Impact Body (item #8) to verify there is no interference. Remove the Ball Retainer Piston and Firing Pin Assembly from the Impact Body and install the O-ring (item #7) onto the Ball Retainer Piston.

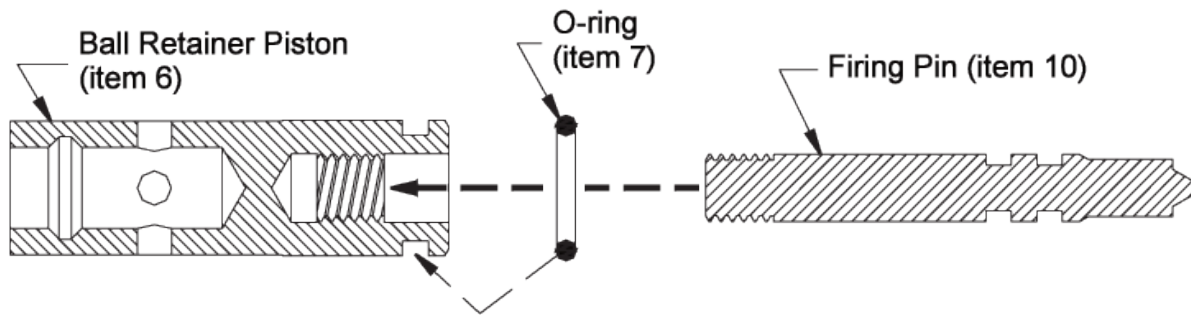

- 1.4 Slide the Release Rod into the rod body until the smaller diameter of the rod is visible through the four (4) holes of the body. Place a small amount of grease into each hole and insert the four (4) Retaining Balls (item #5). The Retaining Balls should be flush with the surface of the body.

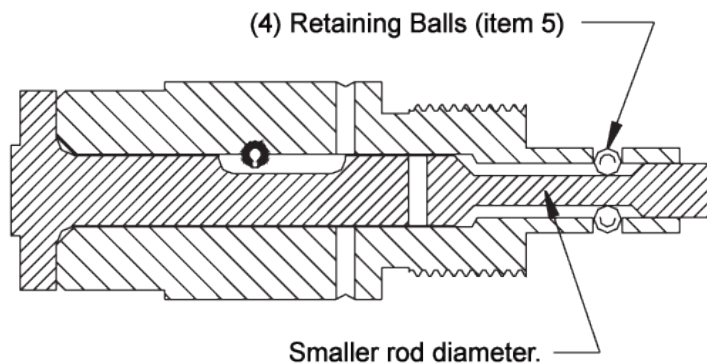

- 1.5 Holding the Release Rod in the rod body, slide the Ball Retainer Piston/Firing Pin all the way onto the rod body. Make sure that the Retaining Balls stay in place.

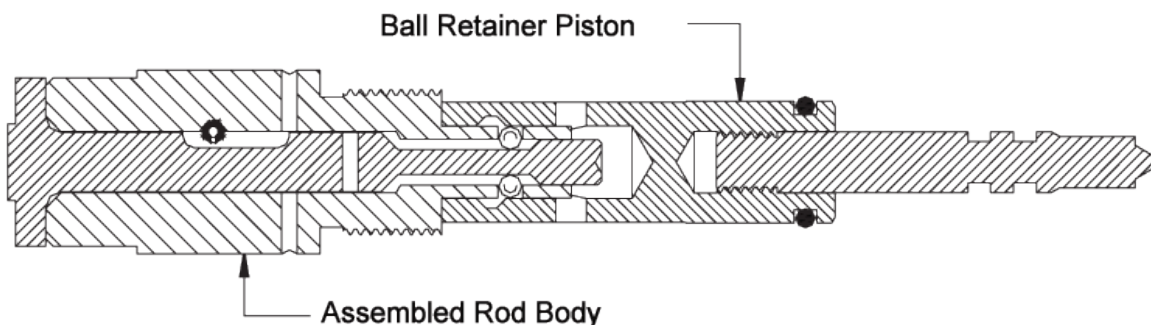

- 1.6** Retract the Release Rod and pull the Ball Retainer Piston away from the body at the same time. This procedure will lock the Retaining Balls into the Ball Retainer Piston and align the Spirol® Coiled Pin holes in the rod body and the Release Rod.

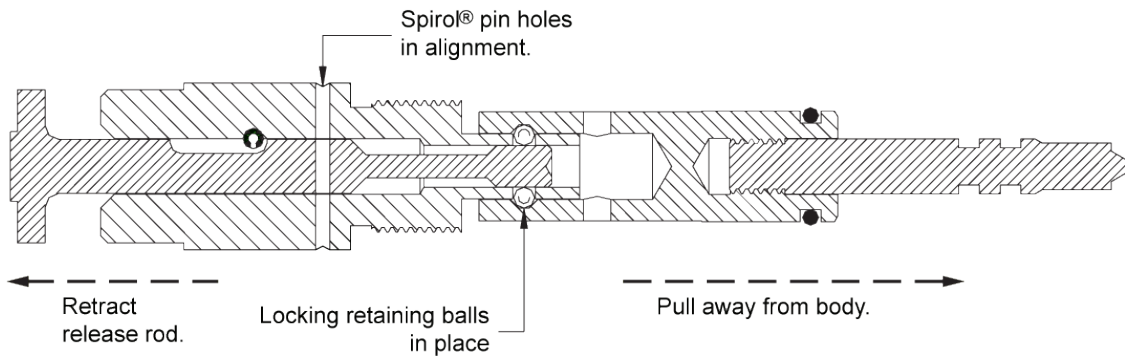

- 1.7** Insert and tap in the Spirol® Coiled Pin (item #4) thru the pin holes on the rod body and Release Rod. Remember to keep the holes aligned during this procedure.

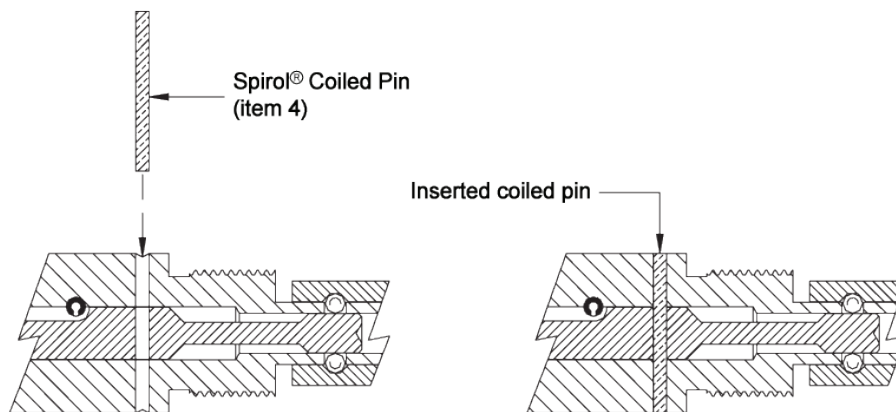

- 1.8** Install the O-rings (item #9) onto the Impact Body (item #8). Apply some grease to the threads of the Release Rod Body and the O-ring on the Ball Retainer Piston, then insert and thread into the Impact Body and tighten.

