



**TECHNICAL INFORMATION:**

**BPX-3500-0093-3003, 3.5 INCH 9.3 PPF**



CASING O.D. (in)	3.5
CASING WT. (lb/ft)	9.3
CASING I.D. (in)	2.992
MAX. RUNNING O.D. (in)	2.716
DIFFERENTIAL PRESSURE RATING (PSI)	5000
TEMPERATURE (F)	350

QTY.	DESCRIPTION	PART NUMBER	MATERIAL
	BPX-SPAN SYSTEM	BPX-3500-0093-3003	NOTED
1	TOP SWAGE	SPC-3500-0093-2110	17-4 PH STAINLESS
1	PIN ELEMENT ASSEMBLY - HNBR	SPC-3500-0093-2213	304L SOLUTION ANNEALED
1	PROFILE SUB	STX-3500-0093-3450	P110 SUPER/HYPER CHROME
1	CAP	BPX-3500-0093-3020	13-Cr
2	O-RING	OOO-V569-142	VITON
2	O-RING	OOO-V569-143	VITON
1	43K SHEAR STUD	PAT-3500-743	STL-12L14

MINIMUM REQUIRED EQUIPMENT REQUIRED.

**PRODUCT OFFERINGS:**

Owen's BPX-SPAN® bridge plug uses the patented and proven X-SPAN® technology to create a mechanical seal that anchors itself to the casing wall when set. The BPX-SPAN is a great solution for wells with hostile environments that may cause elastomers to swell on conventional bridge plugs while being deployed in the wellbore. The BPX consists of a profile sub and a bull plug and utilizes standard Owen setting equipment when being deployed and set into the wellbore.

**BENEFITS/CAPABILITIES:**

- Proven seal technology
- Sets in most grades of casing up to P-110
- Short design for quick removal
- No moving parts, slips, shear screws, set screws that can result in failure during run-in and setting
- Can be converted to knock-out plug with Ceramic disc sub
- For temporary or permanent service
- Can be manufactured in a variety of materials

© 2018 Owen Oil Tools All Rights Reserved

**TECHNICAL INFORMATION:**

### BPX-3500-0093-3003, 3.5 INCH 9.3 PPF

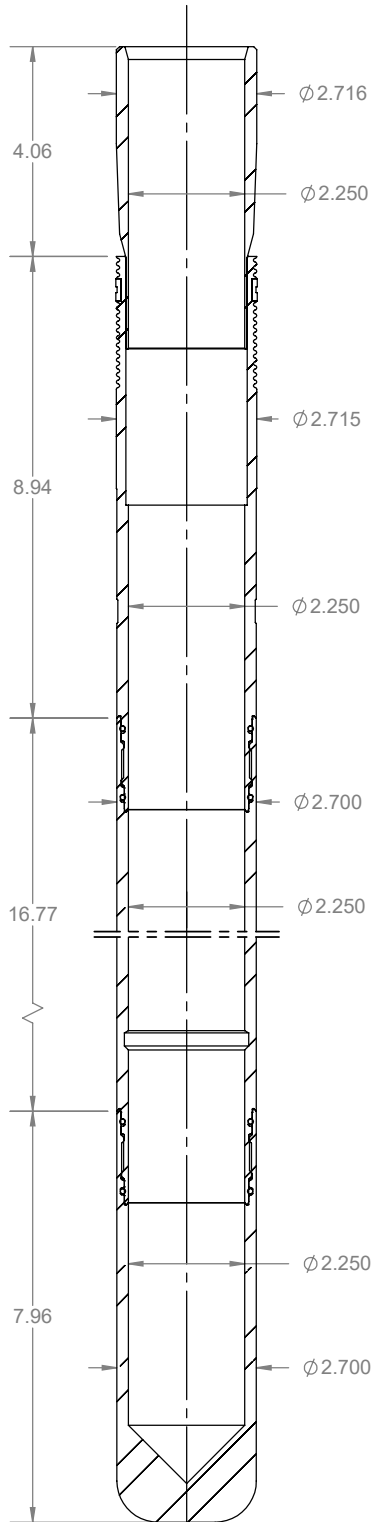

CASING O.D. (in)	3.5
CASING WT. (lb/ft)	9.3
CASING I.D. (in)	2.992
MAX. RUNNING O.D. (in)	2.716
DIFFERENTIAL PRESSURE RATING (PSI)	5000
TEMPERATURE (F)	350

QTY.	DESCRIPTION	PART NUMBER	MATERIAL
1	PIN ELEMENT ASSEMBLY - HNBR	SPC-3500-0093-2213	304L SOLUTION ANNEALED
1	TOP SWAGE	SPC-3500-0093-2110	17-4 PH STAINLESS
1	PROFILE SUB	STX-3500-0093-3450	P110 SUPER/HYPER CHROME
1	CAP	BPX-3500-0093-3020	13-Cr
2	O-RING	OOO-V569-142	VITON
2	O-RING	OOO-V569-143	VITON
1	RELEASE RING ADAPTER	SET-2125-145	4130/4140/4142
1	42 - 43K SHEAR RING	PAT-3500-058	1026
1	SLEEVE NUT	SET-2687-130	4140/4142
1	SLEEVE LOCK NUT	SET-2125-121	4130 / 4140 / 4142
1	SETTING SLEEVE	SET-2125-160L	4140
1	TOP ADAPTER ROD	SET-2125-132	4130 / 4140 / 4142
1	ROD TANDEM CONNECTOR	SET-2125-133	4130 / 4140 / 4142
1	BOTTOM ROD	SET-2125-136	4130 / 4140 / 4142
1	COLLET	SET-2125-161	4130/4140/4142
1	COLLET SUPPORT	SET-2125-155	4130/4140/4142

**MINIMUM EQUIPMENT REQUIRED**



**EXTENSION SPECIFICATIONS:**

**BPX-3500-0093-3003, 3.5 INCH 9.3 PPF**

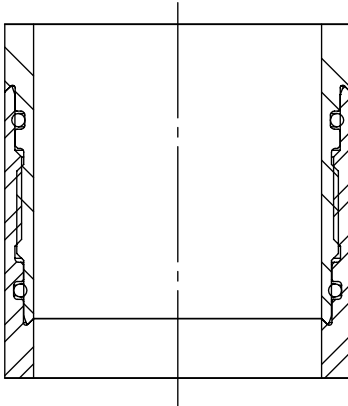

PART NUMBER	WEIGHT (LBS.)	MATERIAL
SPC-3500-0093-2213	4.1	304L SOLUTION ANNEALED

TENSILE RATING	35000 LBF.
----------------	------------

**SYSTEM WEIGHTS**

	WEIGHT (LBS.)
BPX-3500-0093-3003	19.6

**SETTING TOOL OPTIONS:**

HYDRAULIC			WEIGHT (LBS)
2-11/16 HYDRAULIC	SET-2687-200		150
	SCREEN SUB	OTO-798-288A	
	CIRCULATION SUB	SET-2875-010	
	DUMP SUB	SET-2125-200	

PYROTECHNIC			WEIGHT (LBS)
2-11/16 MSST	SET-2687-101		90
	POWER CHARGE	JEC-5306-127	
		OPC-2750-000-LS	
	IGNITER	DET-5306-074	
		DET-5306-008	