

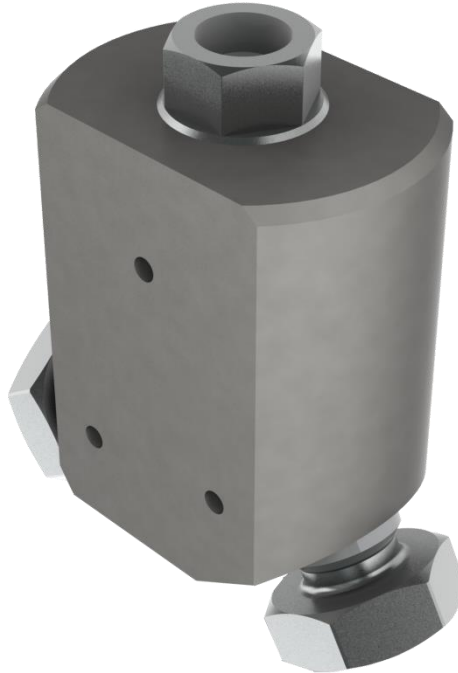

Micro valves



General Features

Design of ST Micro valves is based on the historical free ball system, updated with the aim to eliminate what users were complaining.

- We decided to remove the platen and weld it to the body's valve in order to avoid any leakage from the circuit outside of the valve.
- The free ball gets a new design and it has been also welded to the platen, the closing hole also get a new shape in order to be used several times without parts change.

Specifications	
Working pressure	500 bar
Working temperature	10 to 700°C
Material	Stainless steel
Dimensions	Ø15 mm x 18.5 mm long
2 holes on the top for membrane connection and pressure inlet	
Closing system	
Controlled by a Ø4 mm screw fixed on removable cap	



Micro valves

Characteristics

The major troubles from existing micro valves on the market are the following:

- **The free ball micro valves:** on this valve, the main problem is coming from the big risk of leakage due to the assembling. In fact, one part of this valve insure 2 functions (seals the system from outside, and seals both circuit after closing). The platen is so fragile and closing torqs not controlled. It does mean that users prefer change parts (platen, ball, O-ring) each time the start a new experimentation.
- **Swagelok valves:** These valves are quite reliable, but too large for entering in a cryostat, too large for entering in a Gas Loading System. They just can give good result at ambient for solid sample. Thus, the using is really limited.
- **Small needle valves:** Theoretically, that's a great idea to miniaturize a needle valve, .except that needle valves get all the same problems and that it's impossible to get the same torque closing. The needle finally leaks after few run. Furthermore, the sealing system does not work in cryostat uses.

For these reasons, many users asked for a new design of micro-valves and we decided to:

- Remove the platen and weld it to the body's valve in order to avoid any leakage from the circuit outside of the valve.
- Develop a new design for the free ball. It has been also welded to the platen, the closing hole also get a new shape in order to be used several times without parts change.

